

Meta[®]
DESIGN

PERSONALIZZA
LA TUA
COMODITÀ

CUSTOMIZE
YOUR
COMFORT

SU
MISURA_
TAILOR-
MADE
2023

DIVANI SOFAS

AIR	16
BEST	22
DIALOGO	28
TOPAZIO	34
ZAFFIRO	38
COLORADO	44
JAZZ	52
OLIVER	60
OPERA	68
SINFONIA	80
VERTICE	94
CAPRI	102
GIADA	106
DOUBLE	110
CUBO	118
FLUFFY	128
MONO	136
GULLIVER	142
NEVADA	146
ARIZONA	152
LUX	162
IDEA GIÒ	170
RIALTO	178
MODERN CHESTER	186
CAMBRIDGE	192
OXFORD	198
CLASSIC	204
STUART	214
REVERSE	222
KOSMO	228
HELIOS	234
ALBERT	240
CLOUD	246
CORUS	254
GIM	260
TOKYO	268
MAGÒ	278
MULTI	284
OLIMPUS	294
ROMEO	302
SUPER	308
POUF LAMPO	314

POLTRONE ARMCHAIRS

LUCIA	320
SHEDIR	322
STRADIVARI	326
COLORADO	328
CLASSIC	330
MARIAN	332
OPERA	336
SINFONIA	338

LETTI BEDS

FLY LIGHT	342
JOJOBA	348
MISTRAL	354
MONET	360
MONET PLUS	364
PARIDE	368
CRYSTAL	372
BOSS	376
PRINCE	384
ANTHEA	388
KING	392
ARIA	398
NIVES	402
CLASS	406
DIAMANTE	412
HYPNOS	418
VENEZIA	424
ALEX	430
FLY	434
MARIN	440
PIZZICO	444
TOWER	448
CENTAUREA	452
CLEOPATRA	458
ARALDO	462
IAGO	466
OLIVIERO	470
OTTAVIO	474
GIOTTO	478
GLOBE	484
OTELLO	488
OTELLO LUXURY	492
RONDO	496
OTELLO SOMMIER	502
OTELLO SOMMIER	506
MOTORIZZATI	

ACCESSORI ACCESSORIES

SISTEMI DI RETE OPZIONALI / OPTIONAL NET FRAME SYSTEM	508
TECNICA LETTI / BED FEATURES	514
PIEDINI LETTO / BED FEET	518
CUSCINI / CUSHIONS	522
SPECCHIERE / MIRROIRS	526

Meta[®]
DESIGN

LA QUALITÀ
DI PERSONALIZZARE
LA QUALITÀ _
THE QUALITY
IN CUSTOMIZING
THE QUALITY _

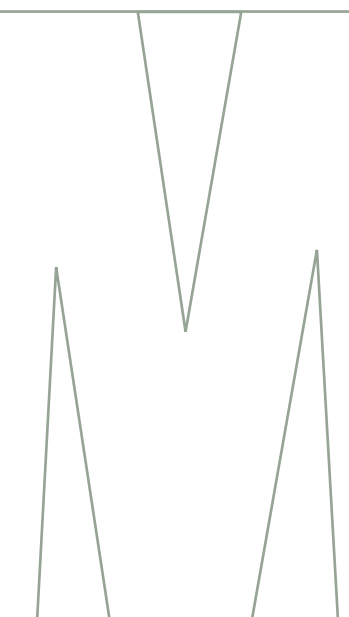



INTERAMENTE REALIZZATI IN ITALIA_ *ENTIRELY MADE IN ITALY_*

OGNI PRODOTTO META DESIGN È INTERAMENTE REALIZZATO IN ITALIA.

Questo impegno per la produzione locale, dalla struttura all'ultima cucitura, aiuta a garantire e a mantenere la tradizione secolare dell'Artigianato dei mobili imbottiti che è alla base del nostro stile italiano e che caratterizza ogni realizzazione di Meta Design. L'etichetta apposta nei nostri prodotti certifica il reale "Made in Italy", con la qualità che tale distinzione assicura.

EACH PRODUCT META DESIGN IS ENTIRELY MADE IN ITALY.

This commitment to local production, from the structure to the last seam, helps to ensure and to maintain the centuries-old tradition of Craft of upholstered furniture that is the basis of our Italian style that characterizes every creation of Meta Design. The label in our products certifies the real "Made in Italy", with the quality that this distinction guarantees.



L'ARTIGIANALITA' SI TRASFORMA IN ARTE_ CRAFTSMANSHIP WHICH BECOMES ART_

ARTE E ARTIGIANALITÀ
SONO DUE CONCETTI
CHE NOI "CUCIAMO" INSIEME.

Perché la nostra artigianalità è un'arte. Tre decenni di esperienza, tre decenni di passione ed esperienza, elevano la nostra lavorazione artigianale a una dimensione artistica. L'arte di lavorare ancora a mano ogni pezzo, dotandolo di una qualità che viene da lontano, nel tempo, per durare nel tempo.

ART AND CRAFTSMANSHIP
ARE TWO CONCEPTS THAT
WE "SEW" TOGETHER.

Because our craftsmanship is an art. Three decades of experience, three decades of passion and experience, raises our hand-crafted production in an artistic dimension. The art of working each single piece, giving it a quality that comes from far away, to last in time.



UN GRANDE PASSATO HA BEN PRESENTE IL FUTURO _ *AN IMPORTANT PAST IS AN AWARENESS OF THE FUTURE _*

**E' DA 30 ANNI
CHE DALLE NOSTRE MANI
PRENDONO FORMA DIVANI.**

Un lungo percorso di arte-artigianale che possiamo definire tradizione.
Un retroterra che si avvale di un grande valore aggiunto, sotto il profilo della sapienza artigianale e del design: il made in Italy. Stiamo quindi scrivendo una storia italiana che ha iniziato il suo quarto decennio.

**IT IS 30 YEARS
THAT OUR HANDS
SHAPE SOFAS.**

A long journey of art and craft that can be defined tradition.
A background that makes use of a high added value, in terms of craftsmanship and design: Made in Italy. We are therefore writing an Italian story that began its fourth decade.





SU MISURA TAILOR MADE

ELEMENTI REALMENTE
SU MISURA PER TUTTI
GLI AMBIENTI_
*ELEMENTS ACTUALLY
TAILOR MADE
FOR ALL AMBIENCES_*

IL NOSTRO CONCETTO DI "SU MISURA"
È REALE, PRECISO, PRAGMATICO.

Perché siamo in grado di trasformare ogni elemento della nostra collezione sulla base delle dimensioni e forme degli ambienti più diversi. Misurandoci con tutte le misure.

OUR "TAILOR MADE" CONCEPT
IS REAL, ACCURATE, PRAGMATIC.

Because we are able to transform every element of our collection according to the dimensions and shapes of the different ambiances. Measuring ourselves with all measurements.

LA PRIMA
SCELTA
È POTER
SCEGLIERE_
*THE FIRST
CHOICE
IS TO BE ABLE
TO CHOOSE_*



**DIVANI
UNICAMENTE
MOLTEPLICI_**

**UNIQUE
MULTIPLE
SOFAS_**

**IL NOSTRO PUNTO
DI PARTENZA**

è sempre la grande molteplicità di scelta in termini di design e dimensioni. Il nostro punto d'arrivo è l'allargamento al massimo grado di questa scelta, attraverso la personalizzazione, Fino alla moltiplicazione unica.

OUR STARTING POINT

is always the wide variety of choice in terms of design and dimensions. Our point of arrival is the enlargement to the highest degree of this choice, through personalization, to the single multiplication.

AIR_

DESIGN R&S_ META DESIGN_

AIR è l'ispirazione che nasce dalla traduzione in senso figurato della parola stessa, sensazione. La sensazione che avvolge chi guarda questo spettacolare modello di divano è quella di stupore e curiosità. La sua molteplice adattabilità agli ambienti e la sua straordinaria capacità compositiva lo rendono un elemento indispensabile per chi vuole rendere il proprio ambiente sensazionale. AIR è la sensazione più bella che potrete vivere nel vostro salotto.

AIR is the inspiration that comes from the figurative translation of the word itself, sensation. The feeling that envelops those who look at this spectacular sofa model is that of amazement and curiosity. Its multiple adaptability to environments and its extraordinary compositional ability make it an indispensable element for those who want to make their environment sensational. AIR is the best feeling you can experience in your living room.

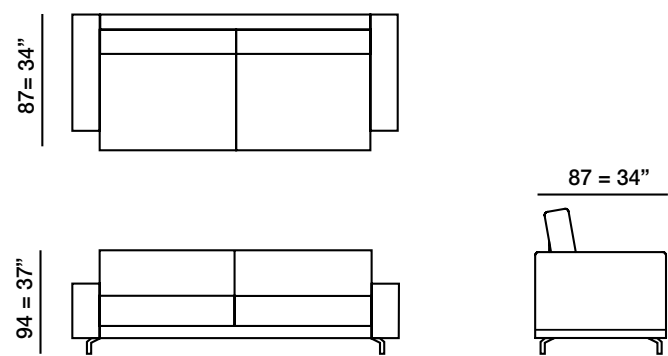





BEST_

DESIGN R&S_ META DESIGN_

BEST, dall'inglese "il migliore" è stato realizzato per offrire il meglio sotto ogni punto di vista. Le forme, il comfort e le dimensioni perfettamente equilibrate, fanno di questo elemento d'arredo il miglior divano sul quale si possa immaginare di trascorrere il proprio tempo. In compagnia di un buon libro, con la famiglia, con gli amici, oppure più semplicemente per ammirarlo, il modello BEST sarà l'elemento di design che darà unicità ad ogni attimo che trascorrerete in sua compagnia.

BEST, from the English "the best" was created to offer the best from every point of view. The perfectly balanced shapes, comfort and dimensions make this piece of furniture the best sofa on which you can imagine spending your time. In the company of a good book, with family, friends, or simply to admire it, the BEST model will be the designed element that will give uniqueness to every moment you spend in its company.

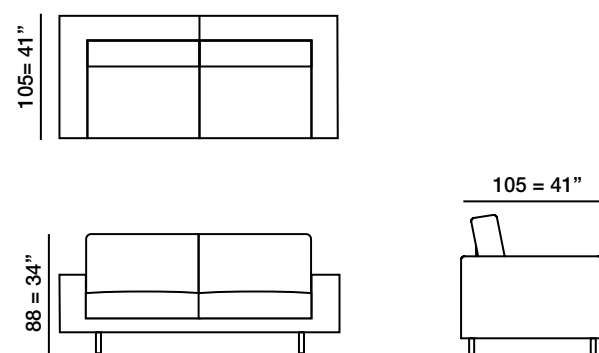





BEST_

DIALOGO_

DESIGN R&S_ META DESIGN_

Tutti amano una buona conversazione, con amici, parenti, conoscenti, sia essa basata su racconti del passato, del presente o sulle ambizioni future. DIALOGO nasce dall'idea di poter creare un elemento di design che possa essere utilizzato come riferimento per una buona chiacchierata. I nostri designer hanno creato l'inconfondibile linearità e versatilità del modello DIALOGO. Rivestimenti colorati, oppure più rigorosi e austeri lo rendono unico per ogni occasione, quasi come se fosse un abito che da formale si trasforma in informale al semplice variare della componibilità scelta.

Everyone loves a good conversation, with friends, relatives, acquaintances, whether it's based on stories from the past, the present or future ambitions. DIALOGO was born from the idea of being able to create a design element that can be used as a place for a good chat. Our designers have created the unmistakable linearity and versatility of the DIALOGO model. Colored coverings, or more rigorous and austere ones make it unique for every occasion, almost as if it were a dress that transforms from formal to informal by simply changing the chosen modularity.

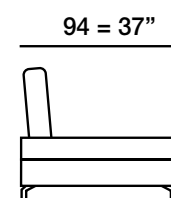
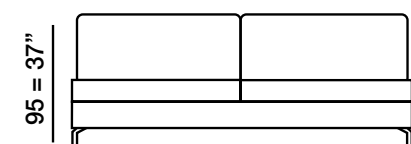
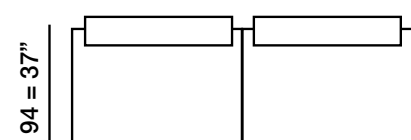





TOPAZIO_

DESIGN R&S_ META DESIGN_

Il TOPAZIO, culturalmente da sempre abbinato alla qualità di trasmettere felicità e favorire l'amicizia ma, soprattutto sottoforma di pietra, è l'elemento naturale che allontana lo stress. Proprio come la pietra del TOPAZIO, il divano ad essa omonimo è in grado di rigenerare e allontanare lo stress accumulato durante una giornata molto intensa. Questo modello di divano è il preferito di chi trascorre molto tempo fuori casa e che interpreta l'imbottito come elemento rigenerante all'interno del contesto domestico. TOPAZIO è la primaria fonte di relax che non dovrebbe mai mancare nel salotto di casa.

TOPAZIO, culturally always combined with the quality of transmitting happiness and fostering friendship but above all in the form of a gem, it is the natural element that drives away stress. Just like the TOPAZIO gem, the sofa bearing the same name is able to regenerate and remove the stress accumulated during a very busy day. This sofa model is the favorite of those who spend a lot of time away from home and who interpret soft furniture as a regenerating element within the domestic context. TOPAZIO is the primary source of relaxation that should never be missing in your living room.

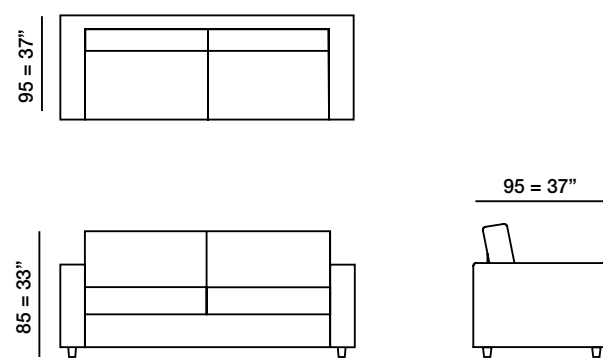



ZAFFIRO_

DESIGN R&S_ META DESIGN_

Unico ed intramontabile, il modello ZAFFIRO è una delle massime espressioni del minimalismo reso funzionalità. Comodo, elegante, giovane, confortevole ... questo divano non stancherà mai per estetica e comfort. La molteplice compatibilità dei rivestimenti e dei colori disponibili lo rendono un complemento d'arredo indispensabile per ogni tipo di arredo.

Unique and timeless, ZAFFIRO model is one of the maximum expressions of minimalism made into functionality. Convenient, elegant, young, comfortable ... this sofa will never tire for aesthetics and for comfort. The multiple compatibility of the upholsteries and colors available make it an indispensable piece of furniture for any type of furnishings.

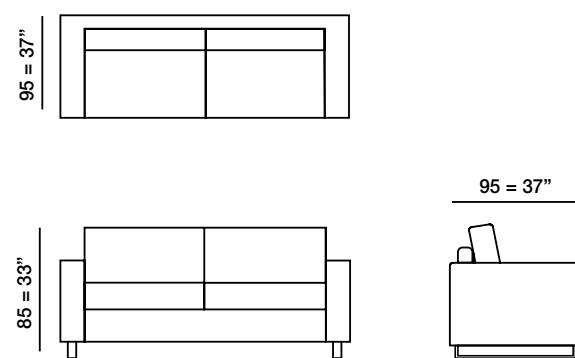



ZAFFIRO



ZAFFIRO

COLORADO_

DESIGN R&S_ META DESIGN_

Vi siete mai chiesti se esista un divano in cui voi possiate scegliere di personalizzare tutto ciò che volete? Bene, COLORADO è la risposta che fa per voi. In questo divano molto comodo, in piuma, avrete infatti la possibilità di personalizzare anche il basamento del divano, col colore RAL che più si abbina ai colori della vostra casa.

Have you ever wondered if there is a sofa where you can choose to customize anything you wish? COLORADO sofa is the answer. This is a very comfortable sofa, with down filling, allows you to actually customize the base of the sofa, with all RAL colors that best matches the colors of your home.

PERSONALIZZA IL BASAMENTO
CON QUALSIASI COLORE RAL._

PERSONALISE THE METAL STRUCTURE
WITH ANY RAL COLOUR._

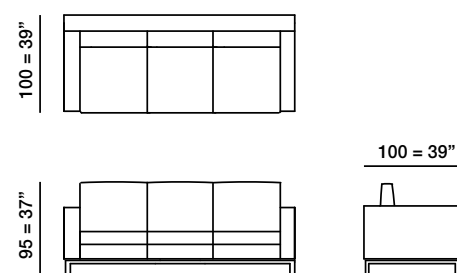



COLORADO



COLORADO



JAZZ_

DESIGN R&S_ META DESIGN_

Come il suono della sua musica che ha ispirato il suo nome, JAZZ è un modello sobrio e caldo contemporaneamente, minimal e di forte personalità nello stesso tempo. Il divano JAZZ ha uno stile intramontabile e grazie alla reversibilità dei cuscini schienali e braccioli si può modificare l'aspetto del divano.

Like the sound of its music that inspired its name, JAZZ is a sober and enveloping sofa, minimal and with a strong personality at the same time. The JAZZ sofa has a timeless style and thanks to the reversibility of its back and armrests cushions you can change the look of the sofa.

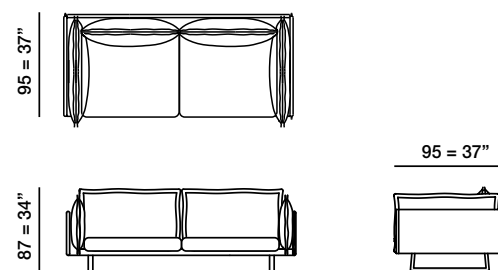



JAZZ_



JAZZ_



COLORE PROFILO GROS GRAIN_
GROS GRAIN TRIMMING COLOURS_

			
COL.40 BIANCO	COL.45 PERLA	COL.63 SENAPE	COL.84 ROSSO
			
COL.83 ARANCIO	COL.65 RUBINO	COL.93 PRUGNA	COL.159 VINO

								
COL.91 MELANZANA	COL.157 VIOLA	COL.154 MOSTO	COL.124 SALVIA	COL.125 OLIVA	COL.136 SABBIA	COL.126 KAKI	COL.168 CASTORO	COL.97 CIOCCOLATO
								
COL.111 COBALTO	COL.104 ORIZZONTI	COL.173 AVIO	COL.116 OCEANO	COL.133 PRATERIA	COL.175 MUSCHIO	COL.51 ATMOSFERA	COL.101 CAFFÈ	COL.41 NERO

OLIVER_

DESIGN R&S_ META DESIGN_

Il nome OLIVER deriva dal latino oliva, frutto del possente albero secolare. Un divano costruito per durare nel tempo, solido, robusto, imponente, ma soprattutto versatile grazie ai suoi poggiatesta e alle sedute estraibili. Il divano OLIVER è nato garantire il massimo del comfort e per resistere alle più lunghe maratone cinematografiche, alle serate fatte di chiacchierate interminabili con gli amici oppure per lasciare libero sfogo alla voglia di relax che solo un divano come OLIVER sa trasmettere.

The name OLIVER derives from the Latin olive, fruit of the mighty secular tree. A sofa built to last over time, solid, robust, imposing, but above all versatile thanks to its headrests and extractable seats. The OLIVER sofa was created to guarantee maximum comfort and to withstand the longest movie marathons, evenings made up of endless chats with friends or to give free rein to the desire to relax that only a sofa like OLIVER can convey.

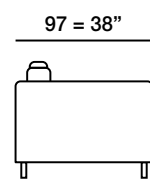
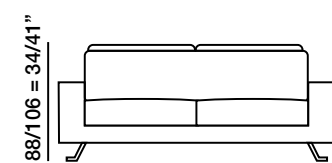
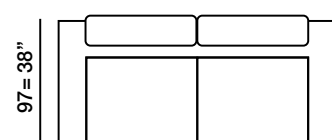



OPZIONE 1 PIEDE METALLO_
OPTION 1 METAL LEG



OPZIONE 2 PIEDE METALLO_
OPTION 2 METAL LEG





BRACCIOLO A_
ARMREST A



BRACCIOLO B_
ARMREST B





OPERA_

DESIGN R&S_ META DESIGN_

OPERA, lo dice la parola stessa, questo divano è una opera dolce e melodiosa. Una linea moderna e classica nel contempo, dove prevalgono le forme arrotondate e curve. Linee che accompagnano e migliorano il nostro comfort ed accentuano in modo gradevole l'aspetto ergonomico. OPERA è stata concepita per coloro che amano il design contemporaneo, l'eleganza ma è anche un divano senza tempo e collocabile in qualsiasi contesto.

OPERA, as the name implies, is a sweet and melodious opera. A modern and classic at the same time, dominated by rounded shapes and curves. Lines that accompany and enhance our comfort and in a pleasant way accentuate the ergonomic features. OPERA has been designed for those who like contemporary design, elegance but it is also a timeless sofa and can be placed in any context.

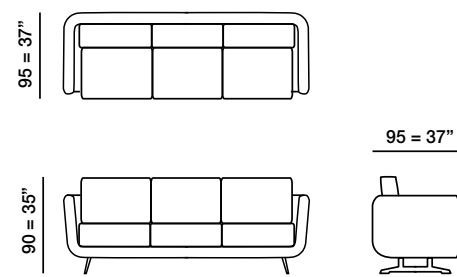





OPERA



OPERA





OPERA_

SINFONIA_

DESIGN R&S_ META DESIGN_

Contemporaneo, moderno e confortevole tre aggettivi che meglio esprimono le qualità di questa linea, ma il quarto aggettivo lo rende unico, la sua profondità ridotta mantiene il confort di una seduta eccezionalmente profonda. Lo schienale sottile è un elemento caratterizzante ed è arricchito da cuscini con cuciture orizzontali, che regalano ancora più eleganza a questa collezione. La seduta è molto avvolgente e confortevole. SINFONIA offre 3 tipi di braccioli: sottile come lo schienale, medio ed anche contenitore dove all'interno possiamo inserire un vassoio verniciato, porta oggetti.

Contemporary, modern and comfortable three adjectives that best express the qualities of this line, but the fourth adjective makes it even more exceptional: its reduced deepness nevertheless allows to have the confort of unique deep seating. The thin backrest is a distinctive feature and is decorated with pillows with horizontal seams, which offer even more elegance to this collection. The seat is very enveloping and comfortable. SINFONIA offers 3 types of armrests: thin as the back, medium and a container armrest as well where we can insert a metallic tray, for objects.

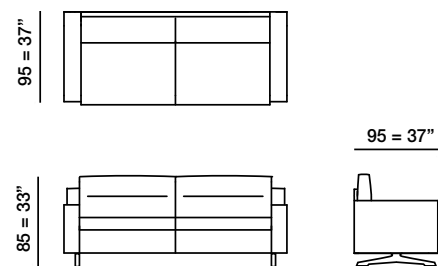





SINFONIA





SINFONIA



SINFONIA



BRACCIOLO A_
ARMREST A



BRACCIOLO B_
ARMREST B



BRACCIOLO CONTENITORE_
STORAGE ARMREST



VERTICE_

DESIGN R&S_ META DESIGN_

VERTICE si presenta tradizionalmente da due o tre posti con angolo e piedini in acciaio a V, con la possibilità di comporlo o meno con la penisola. Caratteristica principale sono i braccioli inclinati e i bordi sporgenti sul retro, che donano comfort e qualità alla seduta.

VERTICE traditionally presents itself as a two or three-seater with corner and V-shaped steel feet, with the possibility of composing it with or without chaiselongue . The main feature are the inclined armrests and the protruding edges on the back, which give comfort and quality to the seat.

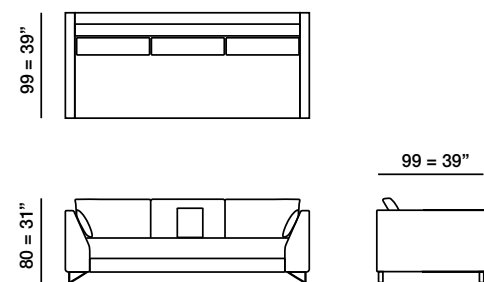





VERTICE_



VERTICE

CAPRI_

DESIGN R&S_ META DESIGN_

CAPRI è un divano caratterizzato dalla linearità che gli conferisce uno stile senza tempo. Rifugio per il relax come l'omonima isola gioiello, è sinonimo di arte e cultura. Il divano CAPRI viene realizzato con tutta la cura dei nostri artigiani, artisti della tappezzeria e della manifattura. La sua modularità, costituita da una vasta gamma di elementi che gli permette di trasformarsi in divano di varie misure o poltrona. CAPRI è dunque totalmente personalizzabile e adattabile ad ogni ambiente, dove l'eleganza e lo stile sono elementi essenziali del dress code.

CAPRI is a sofa characterized by linearity that gives it a timeless style. Refuge for relaxation like the jewel island of the same name, it is synonymous of art and culture. The CAPRI sofa is made with all the care of our craftsmen, upholstery and manufacturing artists. Its modularity, made up of a vast range of elements, which allows it to transform into a sofas of different dimensions or armchair. CAPRI is therefore totally customizable and adaptable to any environment, where elegance and style are essential elements of the dress code.

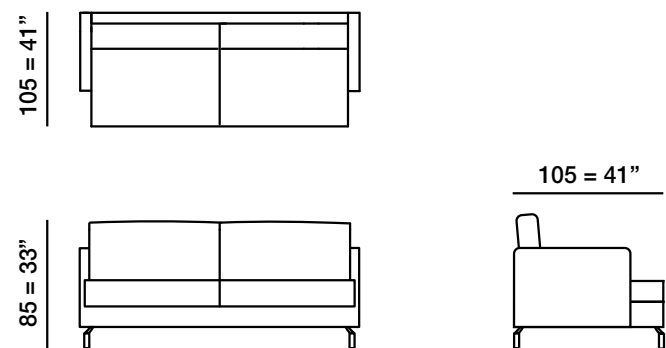



CAPRI

GIADA_

DESIGN R&S_ META DESIGN_

Proporzioni generose, modularità confortevole e un elevato grado di ergonomia rendono GIADA la regina dello spazio living. La collezione completa di laterali, penisole e terminali consentono configurazioni dalle proporzioni ampie, pensate per offrire un livello di confort assoluto. Il piede in metallo cromato non fa che aggiungere carattere al carattere.

Generous dimensions, comfortable modularity and a high degree of ergonomics make GIADA the queen of the living space. The complete collection of sides, chaiselongues and terminals allow spacious configurations, designed to offer an absolute level of comfort. The metal chrome foot emphasizes the beauty of the design.

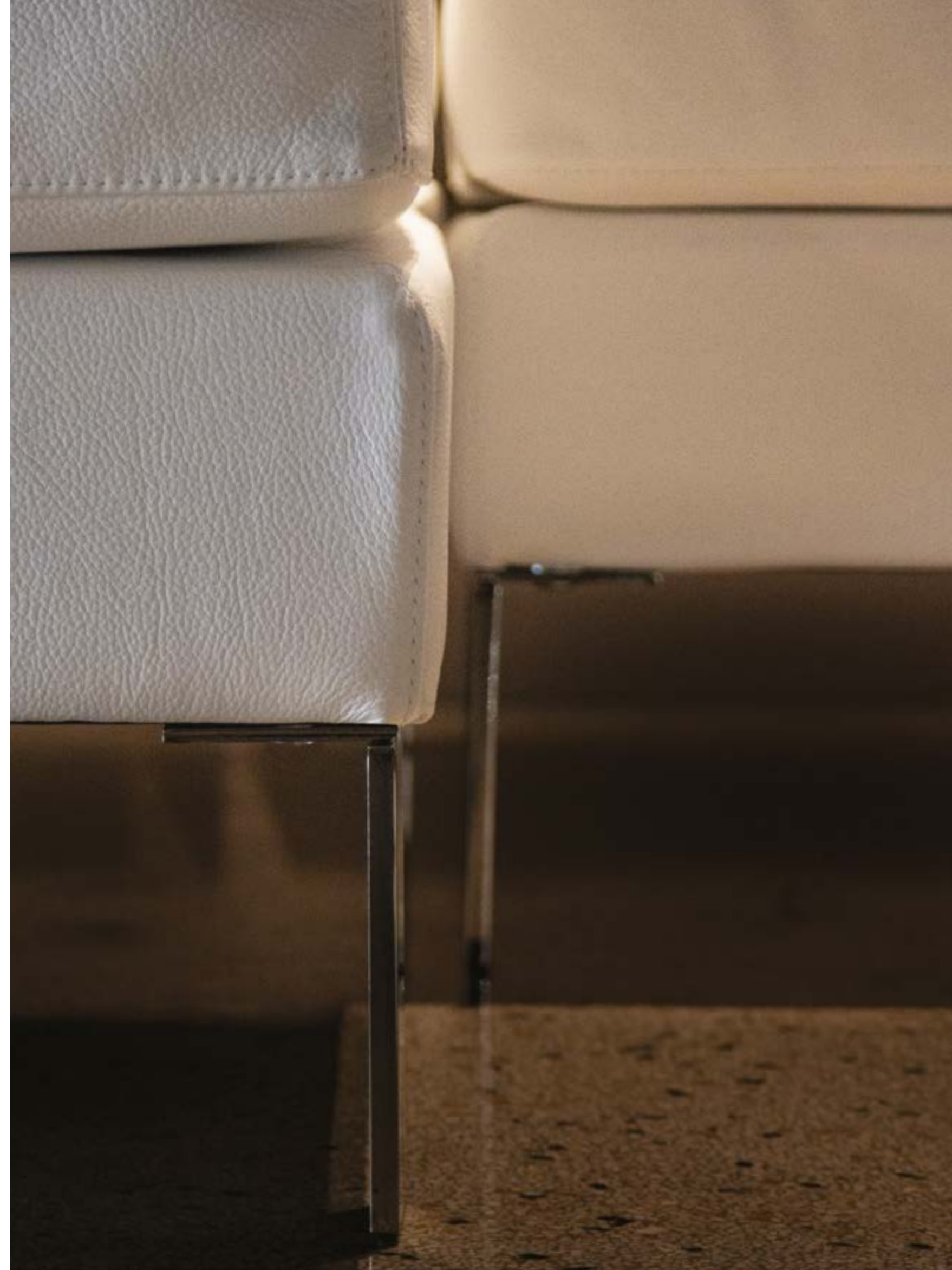
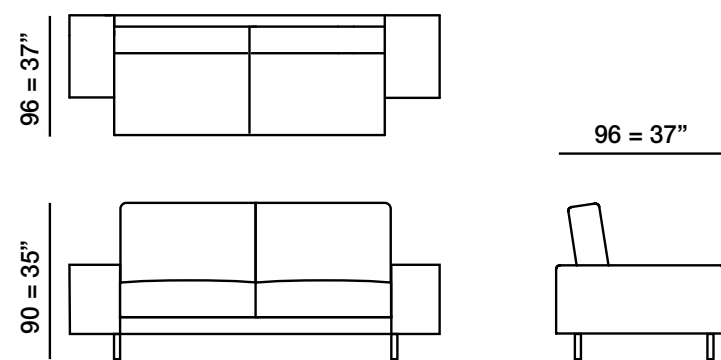



DOUBLE_

DESIGN R&S_ META DESIGN_

Il modello DOUBLE è doppio in tutto, lo dice il nome stesso. Doppia versatilità, doppia comodità, tutto in questo modello si raddoppia. La seduta più profonda lo rende un comodissimo elemento di arredo che sa distinguersi per la sua caratteristica principale, la comodità. Personalizzabile con infinite combinazioni di materiali e colori il modello DOUBLE può essere inserito in contesti prevalentemente moderni dove la linearità e la semplicità delle forme esaltano lo spazio.

The DOUBLE model is double in everything, as the name itself says. Double versatility, double comfort, everything in this model doubles. The deeper seat makes it a very comfortable piece of furniture that stands out for its main feature, comfort. Customizable with infinite combinations of materials and colors, the DOUBLE model can be inserted in predominantly modern contexts where the linearity and simplicity of the shapes enhances the space.

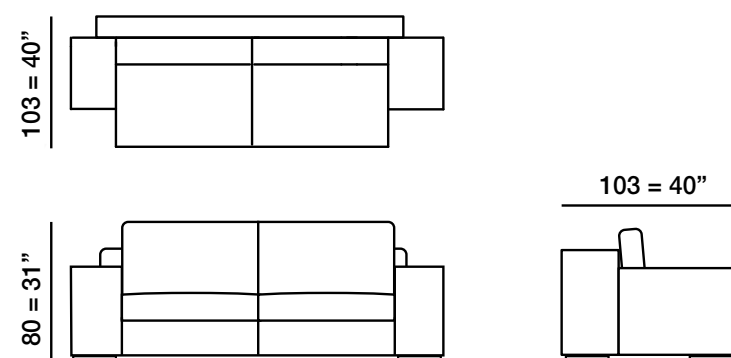





DOUBLE



DOUBLE

CUBO_

DESIGN R&S_ META DESIGN_

Relax e stile nel living con il divano componibile CUBO, un arredo di linea impeccabile che si presenta in forme squadrate ma rilassate, evocando atmosfere piacevoli da condividere nel massimo comfort. Una delle caratteristiche di CUBO è la possibilità di un'ampia gamma di soluzioni compositive per adattarsi ad ogni ambiente.

Relax and style in the living room with sectional sofa CUBO, an impeccable upholstered furniture line that comes in square shapes but with loose design, evoking pleasant atmosphere to share in comfort. One of CUBE's features is the possibility of a wide range of compositions suitable for all environments.

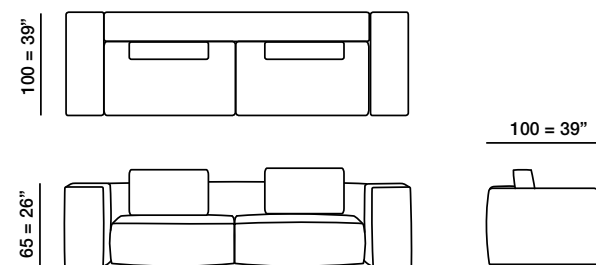



CUBO_



BRACCIOLO A_
ARMREST A



BRACCIOLO B_
ARMREST B





CUBO_



CUBO_

FLUFFY_

DESIGN R&S_ META DESIGN_

All'insegna della morbida accoglienza questo modello dal design lineare e corposo è un sicuro protagonista dell'abitare moderno. Una soffice ed avvolgente seduta che regala giorno dopo giorno intensi momenti di relax. FLUFFY, grazie ai numerosi elementi tra i quali è possibile scegliere, è un divano estremamente versatile, che si adatta ad ogni esigenza di spazio e di stile. FLUFFY può essere composto in molti modi e quindi creare un ampio spazio di comfort.

With a soft welcome, this model with a linear and full-bodied design is a sure protagonist of modern living. A soft and enveloping seat that offers intense moments of relaxation day after day. FLUFFY, thanks to the numerous elements among which it is possible to choose, is an extremely versatile sofa, which adapts to all needs of space and style. FLUFFY can be composed in many ways and thus create a large space of comfort.

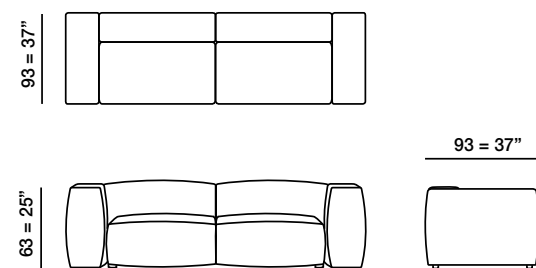



FLUFFY_





FLUFFY_



MONO_

DESIGN R&S_ META DESIGN_

Dal greco MONO, ovvero primo elemento di una serie, questo fantastico divano rappresenta il punto di partenza del design del mondo dell'imbottito. La sua semplicità, la linearità e le forme inconfondibili, lo rendono un elemento che da sempre caratterizza nell'immaginario collettivo la forma del relax. La sua principale caratteristica è l'intramontabilità stilistica e la versatilità nella customizzazione, MONO è l'elemento per eccellenza personalizzabile in ogni suo dettaglio.

From the Greek MONO, the first element of a series, this fantastic sofa represents the starting point of design in the world of upholstery. Its simplicity, linearity and unmistakable shapes make it an element that has always characterized the form of relaxation in the collective imagination. Its main feature is its stylistic timelessness and versatility in customization, MONO is the element par excellence that can be customized in every detail.

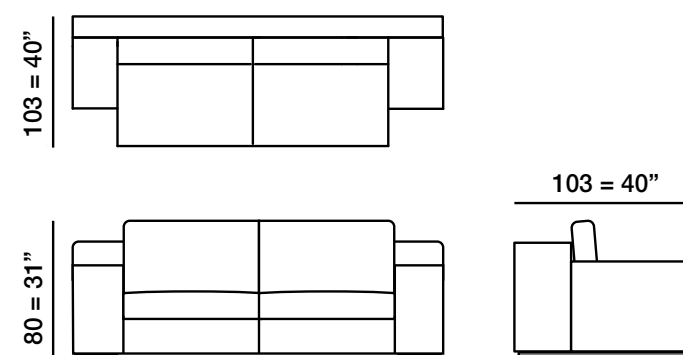



MONO_



MONO

GULLIVER_

DESIGN R&S_ META DESIGN_

Modello "imponente", dal design evoluto ed attuale.

Utilizza materie prime di assoluto pregio sia nella struttura che nella cuscinatura.

Curato con certissima attenzione in ogni sua lavorazione, GULLIVER si propone con una componibilità essenziale: 2 posti e 3 posti. In perfetto abbinamento, qualora lo vogliate, con la poltrona MARIAN, come proposto dall'ambientazione nella pagina successiva.

An "impressive" model, with a modern and up-to-date design.

Using high-quality raw materials both in the structure and in the cushioning. Finished with exceptional attention throughout its manufacturing, GULLIVER proposes essential modularity with 2 seats and 3 seats. In perfect harmony, if you wish, with the MARIAN armchair, as presented in the next page.

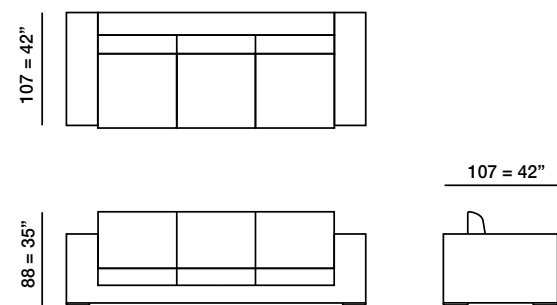



NEVADA_

DESIGN R&S_ META DESIGN_

NEVADA è uno dei divani più d'effetto della collezione META DESIGN. Molto sinuoso e confortevole, grazie alle sedute in piuma, è la soluzione ideale per chi vuole inserire nel proprio salotto un elemento davvero moderno e allo stesso tempo non rinunciare al massimo della comodità.

NEVADA is one of the most impressive sofas of META DESIGN's collection. Very curvy and comfortable, thanks to the feather cushions.

This model is ideal for those who want to include in their living room a very contemporary element without giving up comfort.

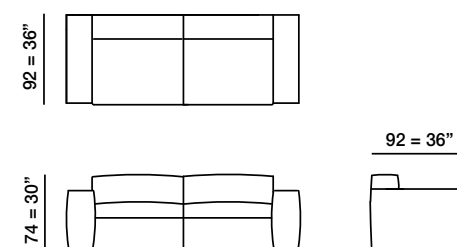



BRACCIOLOA_
ARMREST A



BRACCIOLO L_
ARMREST L





ARIZONA_

DESIGN R&S_ META DESIGN_

ARIZONA è il divano di chi ama la comodità e cerca il design innovativo che si differenzia dalle solite linee moderne. La sua imponenza e il suo carattere lo rendono adatto a conferire agli ambienti il massimo dell'eleganza. Con la morbidezza di ARIZONA potrai garantire alla tua famiglia e ai tuoi ospiti un comfort senza eguali.

ARIZONA is the sofa for those who love comfort and look for innovative design that differs from the usual modern lines. Its grandeur and its character make it suitable for conveying the utmost elegance to all environments. With the softness of ARIZONA you can guarantee your family and guests unparalleled comfort.

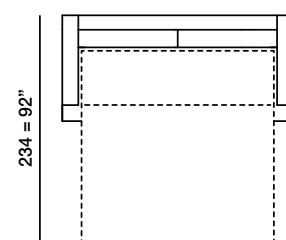
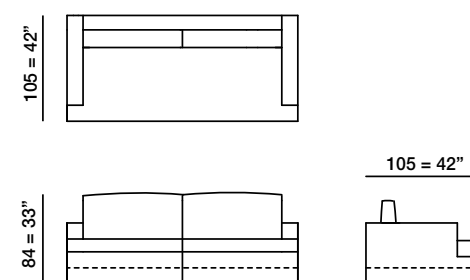







ARIZONA



ARIZONA

LUX_

DESIGN R&S_ META DESIGN_

LUX: Una luce più moderna perché questa linea si arricchisce di profili in rilievo che enfatizza la bellezza di questo modello. Un design più versatile, e presenta un equilibrio estetico tale da armonizzarsi molto bene sia con un contesto classico, sia con un ambiente contemporaneo. La bellezza di un equilibrio eclettico.

LUX: Here comes a more modern light because the model is enriched by embossed piping which enhances the beauty of the sofa. A more versatile design and it presents an aesthetic balance that blends very well both a classical and a contemporary setting. The beauty of an eclectic balance.

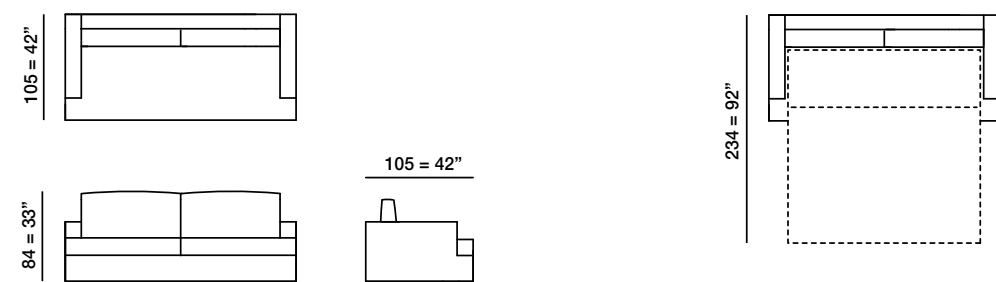





COLORE PROFILO GROS GRAIN_
GROS GRAIN TRIMMING COLOURS_

			
COL.40 BIANCO	COL.45 PERLA	COL.63 SENAPE	COL.84 ROSSO
			
COL.83 ARANCIO	COL.85 RUBINO	COL.93 PRUGNA	COL.159 VINO
			
COL.91 MELANZANA	COL.157 VIOLA	COL.154 MOSTO	COL.124 SALVIA
			
COL.125 OLIVA	COL.136 SABBIA	COL.126 KAKI	COL.168 CASTORO
			
COL.97 CIOCCOLATO	COL.111 COBALTO	COL.104 ORIZZONTI	COL.173 AVIO
			
COL.116 OCEANO	COL.133 PRATERIA	COL.175 MUSCHIO	COL.51 ATMOSFERA
			
COL.101 CAFFÈ	COL.41 NERO		



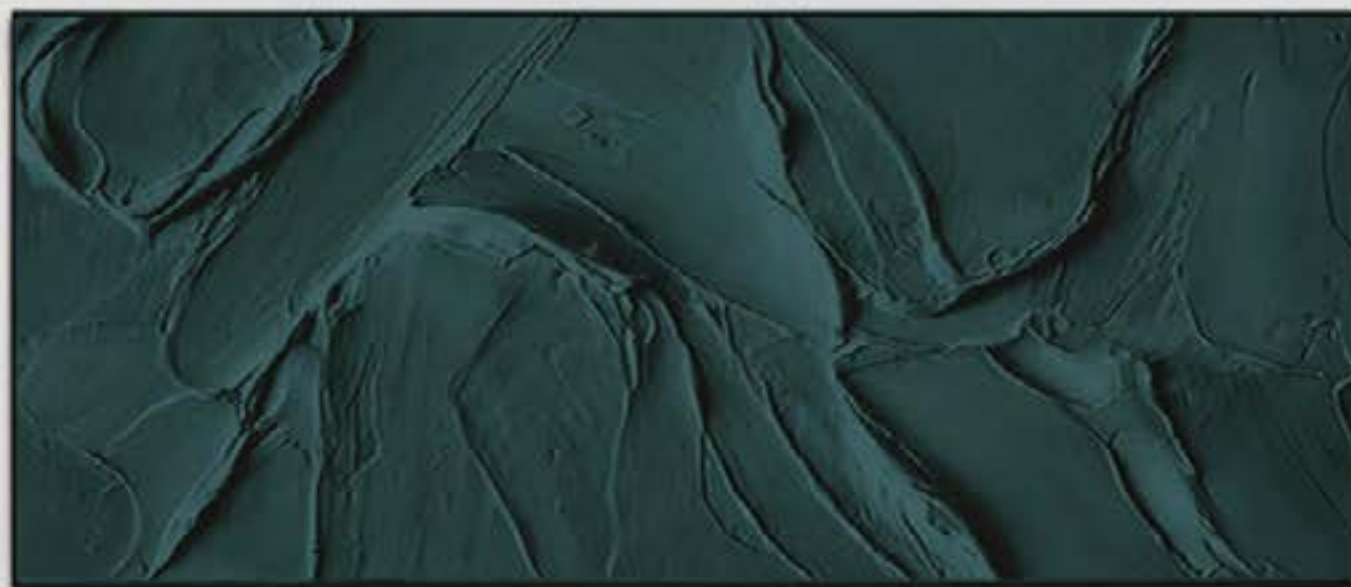

LUX_

IDEA GIÒ_

DESIGN R&S_ META DESIGN_

IDEA GIÒ è la sintesi di un progetto basato sul valore percepibile, sulla consapevolezza che l'estetica deve essere congiunta alla tecnica e alla qualità dei materiali impiegati per appagare la nostra innata ricerca del bello ma anche la nostra gratificazione del contatto sensoriale con materiali nobili. Le forme sono essenziali e possono essere composte in svariati modi mantenendo, anche nelle composizioni più complesse, una ammirevole pulizia di linee, grazie ad un design sobrio ed elegante, frutto di una ricerca dell'armonia e della raffinatezza.

IDEA GIÒ is the synthesis of a project based on perceived values, on the awareness that look must be combined with technique and supported by quality materials, which are used to satisfy our innate quest for beauty as well as to provide us with the pleasure of touching noble materials. Shapes are essentials and can be combined in different ways, while keeping neat lines even in the most complex compositions, thanks to a sober and elegant design resulting from our search for harmony and refinement.

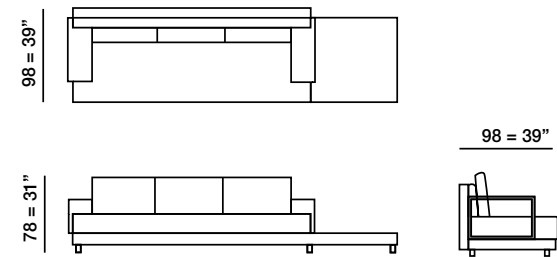





BRACCIOLO CUOIO
HIDE ARMREST



BRACCIOLO CROMATO
CHROME ARMREST





RIALTO_

DESIGN R&S_ META DESIGN_

Studiato per chi ama il massimo comfort, unito ad un design rigoroso e formale.
Il meccanismo relax elettrico permette la distensione della schiena ed il sollevamento delle gambe per raggiungere la posizione di riposo ottimale.

Designed for those who love comfort, combined with a rigorous and formal design.
The electrical relax mechanism allows the back distension and the lifting of the legs to reach the optimal rest position.

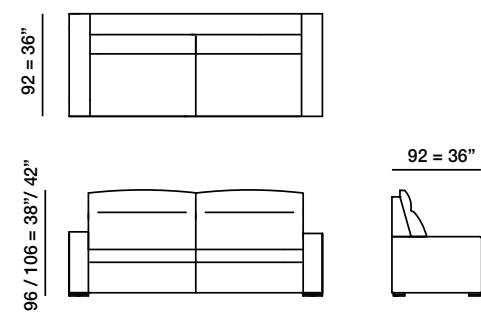



RIALTO_



BRACCIOLO A_
ARMREST A



BRACCIOLO B_
ARMREST B



BRACCIOLO C_
ARMREST C





RIALTO_

MODERN CHESTER_

DESIGN R&S_ META DESIGN_

Design di ispirazione nordica che bene si inserisce in ambienti spiccatamente moderni ma anche in contesti più classici. MODERN CHESTER ha una sinuosità elegante e un carattere cosmopolita. Contrasta sulle forme lineari la lavorazione a mano tipica del capitonné. MODERN CHESTER posa a terra con piedi in legno disponibili in cinque colori.

Nordic-inspired design that fits well in distinctly modern environments but also in more classic contexts. MODERN CHESTER has an elegant sinuosity and a cosmopolitan character. The handwork typical of capitonné contrasts with the linear shapes. MODERN CHESTER is lifted from the ground with wooden feet available in five colors.

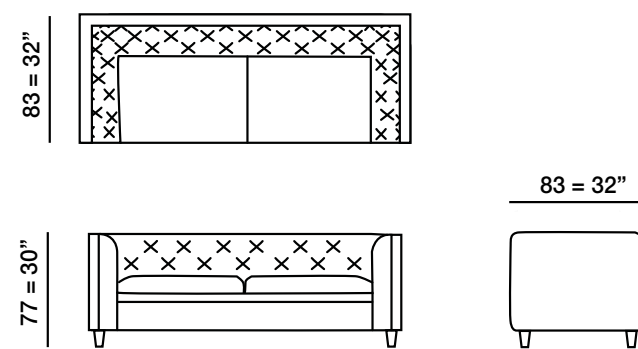



MODERN CHESTER_



MODERN CHESTER

CAMBRIDGE_

DESIGN R&S_ META DESIGN_

In pieno stile Chesterfield, il divano CAMBRIDGE è caratterizzato dal comfort di una seduta profonda e accogliente. Il design del passato e la cura del dettaglio, sapientemente abbinati all'uso dei più moderni materiali, offrono configurazioni con piede rivestito in pelle e piede in ottone, che diventano parti integranti e caratteristiche inconfondibili di questo modello. Due o tre posti, CAMBRIDGE è disponibile anche in formato poltrona.

In full Chesterfield style, the CAMBRIDGE sofa is characterized by the comfort of a deep and welcoming seat. The design of the past and the attention to detail, skillfully combined with the use of the most modern materials, offer configurations with leather upholstered foot and a brass one, which become integral parts and unmistakable features of this model. Two or three seats sofa, CAMBRIDGE is also available in an armchair format.

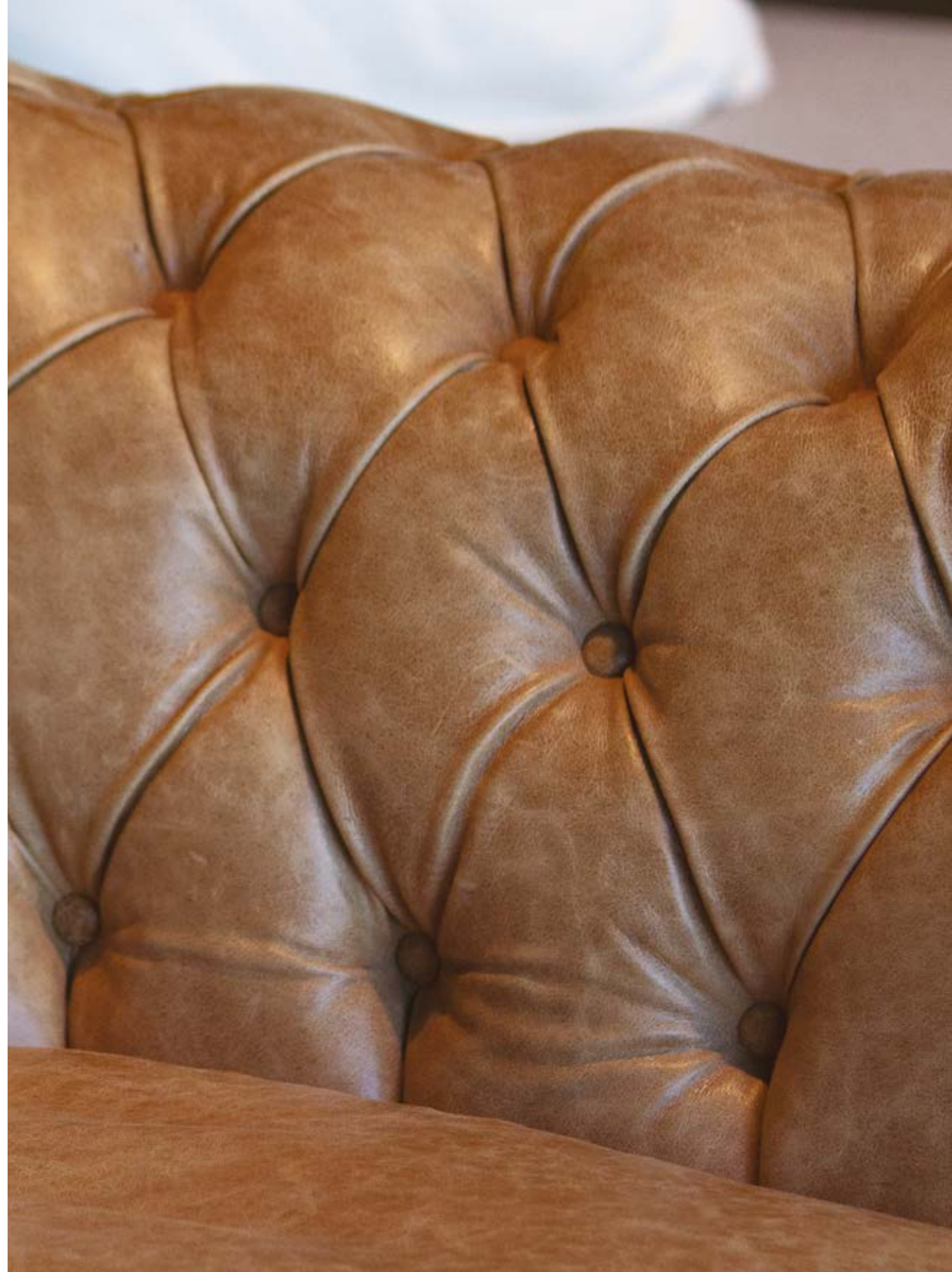
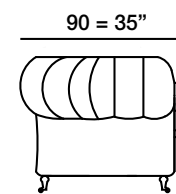
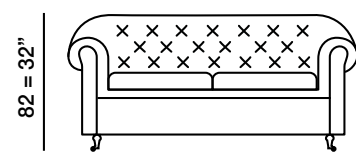
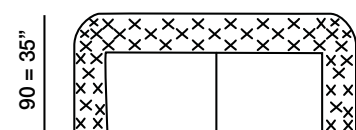





CAMBRIDGE_

OXFORD_

DESIGN R&S_ META DESIGN_

Forme tradizionali e contemporanee abbinate a una sapiente cura dei dettagli sono i tratti caratteriali di OXFORD. Un divano realizzato interamente a mano, dove l'esperienza e l'artigianalità sono le caratteristiche fondamentali dell'alta qualità. La lavorazione capitonné sullo schienale conferisce eleganza e raffinatezza. Sospeso da terra con piedi in legno disponibili in cinque colorazioni, assume un aspetto di leggerezza e praticità.

Traditional and contemporary shapes combined with a skillful attention to detail are the main traits of OXFORD. A sofa made entirely by hand, where experience and craftsmanship are the key features of high quality. The capitonné work on the back gives elegance and refinement. Lifted from the ground with wooden feet available in five colors, it takes on an aspect of lightness and functionality.

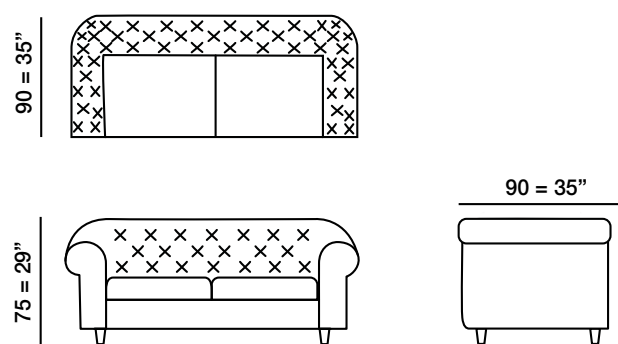





OXFORD

CLASSIC_

DESIGN R&S_ META DESIGN_

Il nome già dice tutto. CLASSIC è design che supera la prova estetica del tempo. CLASSIC è bellezza che oltrepassa la moda. CLASSIC è fascino che non conosce oscillazioni. Ma CLASSIC è anche la prova visibile e materiale della nostra qualità. Così specialisticamente artigianale da diventare artistica. Un'estetica certa e prolungata negli anni.

The name says it all. CLASSIC design that goes beyond the aesthetic time test. CLASSIC beauty that transcends fashions. CLASSIC charm that knows no fluctuations. However, CLASSIC is also a visible proof of our quality and materials. So extremely, craft hand made to become art. CLASSIC is certain and will last for years to come.

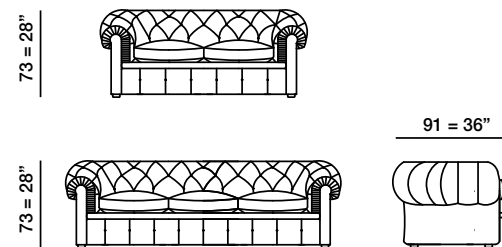



CLASSIC_



CLASSIC_



CLASSIC_



CLASSIC_

STUART_

DESIGN R&S_ META DESIGN_

Personalità è saper incrociare stili, reinventandoli.

STUART esprime tutto il suo carattere ed originalità mescolando lo stile retrò con un design contemporaneo. Proponendo un'avvincente rivisitazione in chiave contemporanea della lavorazione capitonné. E anche il comfort è fortemente moderno, grazie all'ampia dimensione delle losanghe e alla morbida imbottitura.

Personality is the ability to mix styles reinventing them.

STUART expresses all its features and originality by mixing the retro style with contemporary design. Offering a compelling contemporary reinterpretation of capitonné handcrafted. The comfort is highly modern, thanks to the lozenges large size and soft padding.

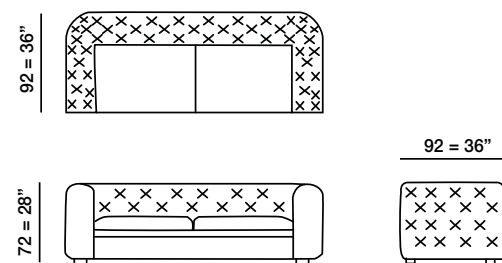



STUART





STUART_



STUART

REVERSE_

DESIGN R&S_ META DESIGN_

Compatto, confortevole ed ergonomico, senza rinunciare a linee moderne. REVERSE è il divano letto che soddisfa le più sofisticate esigenze di design. La seduta diventa un letto singolo trasversale oppure un comodo letto matrimoniale da 160x200 cm semplicemente rimuovendo i morbidi cuscini dello schienale. Grazie al maneggevole meccanismo Lampolet si apre con una mano.

Compact, comfortable and ergonomic, without sacrificing modern lines. REVERSE is the sofa bed that satisfies the most sophisticated design needs. The seat becomes a transversal single bed or a comfortable 160x200 cm double bed simply by removing the soft back cushions. Thanks to the handy Lampolet mechanism, it opens with one hand.

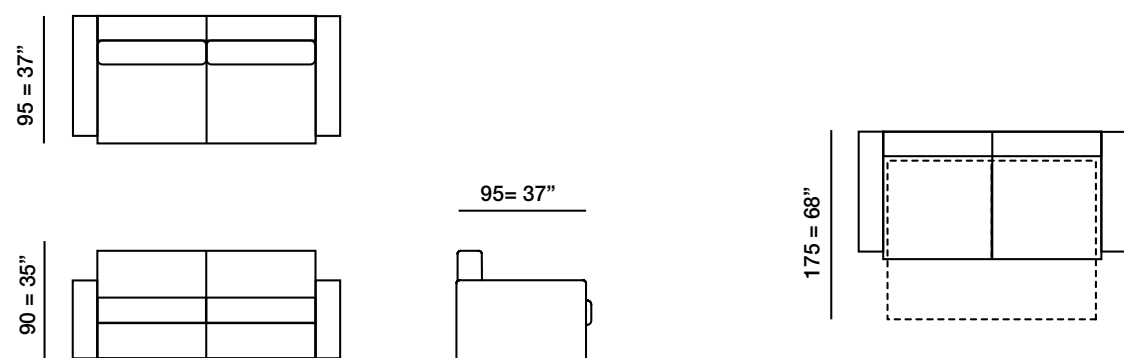





REVERSE

KOSMO_

DESIGN R&S_ META DESIGN_

Modularità ed elementi fissi e trasformabili sono i tratti caratteristici di KOSMO. Questa collezione offre materassi di varie misure, 120,140,160 sino al 180 con lunghezza da 200cm. La sua versatilità gli permette di diventare l'elemento che meglio si adatta all'ambiente in cui è protagonista. Cuscini, schienali e seduta hanno tutti lo spessore di un vero divano: una garanzia di comfort assoluto.

Modularity and transformable and fixed elements are the KOSMO's main features. This collection offers mattresses of various sizes, 120,140,160 up to 180 with a length of 200cm. Its versatility allows it to become the element that best adapts to the environment in which it is the protagonist. Cushions, backrests and seat all have the thickness of a real sofa: a guarantee of absolute comfort.

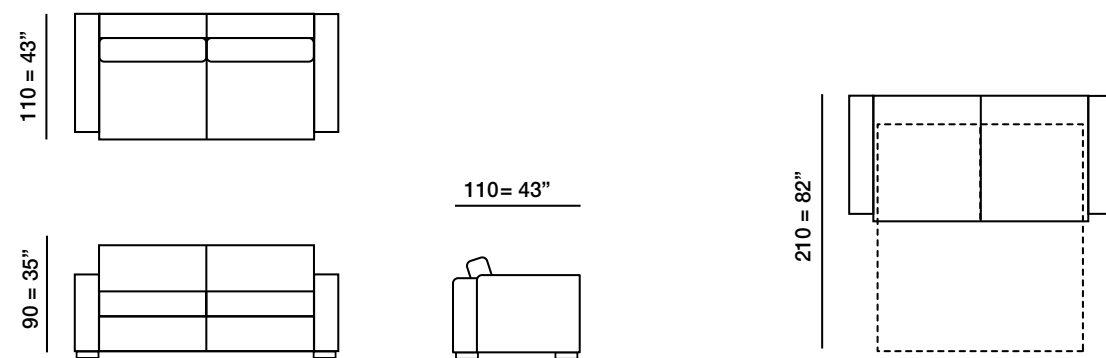





C1



C2



C3

HELIOS_

DESIGN R&S_ META DESIGN_

Con le sue linee rigorose dal concept semplice e raffinato, il divano letto HELIOS soddisfa le più moderne esigenze di ergonomia e design. Attraverso un semplice gesto, si trasforma rapidamente in letto estraendo un confortevole materasso da 200 cm di lunghezza. Modello HELIOS offre una ampia modularità oltre ad un grande comfort.

With its rigorous lines with a simple and refined concept, the HELIOS sofa bed satisfies the most modern needs of ergonomics and design. With a simple gesture, it quickly turns into a bed by pulling out a comfortable 200 cm long mattress. HELIOS model has an extensive modularity besides a great comfort.

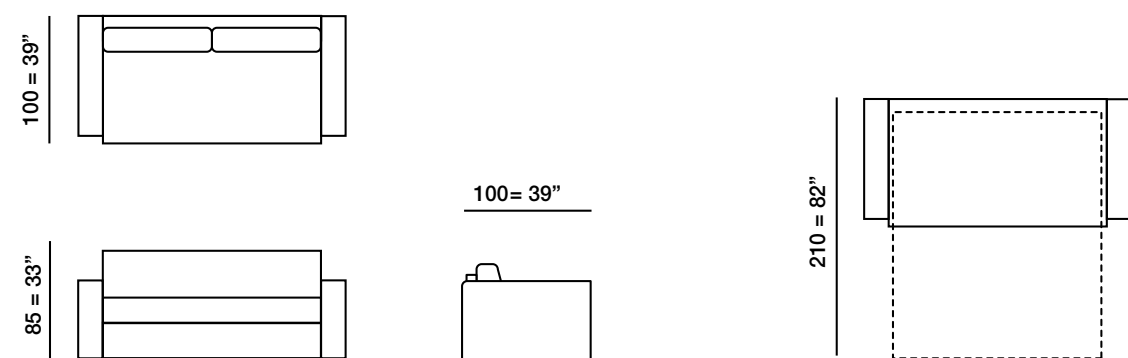





HELIOS_

ALBERT_

DESIGN R&S_ META DESIGN_

Linee moderne e un'ampia scelta di accessori e complementi, fanno di ALBERT un divano versatile, adatto a qualunque esigenza. All'occasione, può trasformarsi in un comodo letto con un ampio spazio contenitore sottoseduta.

Contemporary lines and a wide choice of accessories and complementary items make ALBERT a versatile sofa, to meet all requirement. If necessary, it can be transformed into a comfortable bed or the underneath part of the seat used for storage space.

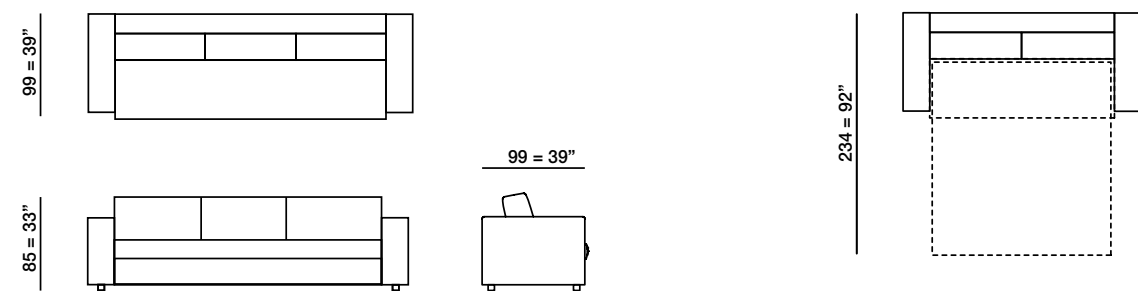



BRACCIOLO A_
ARMREST A



BRACCIOLO L_
ARMREST L





ALBERT_

CLOUD_

DESIGN R&S_ META DESIGN_

CLOUD nasce per coniugare diverse esigenze. Gestì semplici, veloci e accessibili a tutti consentono una totale trasformazione del complemento d'arredo. I meccanismi perfetti, uniti a materiali di alta qualità garantiscono l'ottimizzazione del progetto. Il risultato è dato da eleganza di forme e sapienza meccanica. Gli snodi dei braccioli e la sistemazione dei cuscini-seduta e schienale nell'alloggiamento dedicato, ancora una volta razionalizzano lo spazio e organizzano l'ambiente. I dettagli delle cuciture e rifiniture, collocano il prodotto nella fascia alta dei trasformabili. Il rivestimento può essere scelto tra diverse pelli e tessuti con cromie forti o delicate. CLOUD è totalmente sfoderabile nella versione tessuto.

CLOUD was conceived to conjugate different needs. The perfect mechanism, together with high quality materials guarantee the project optimization. The result is given by the elegance of the shapes and the mechanical content. The armrests' folding system, the cushion-seating and the back in its allotted space once again rationalizes the space and organizes the environment. The details of the stitching and the trimmings place the product in the highest level of the transformable. The upholstery can be chosen between different leathers and fabrics with strong or delicate tones. In the fabric version, CLOUD's upholstery is entirely removable.

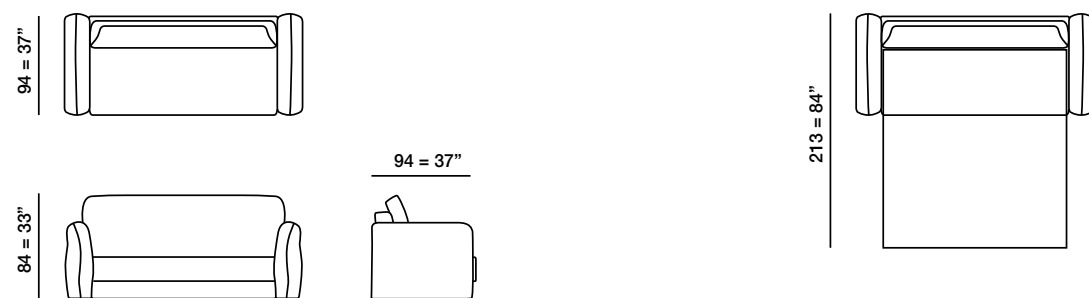



CLOUD_





CLOUD_



COLORE PROFILO GROS GRAIN_
GROS GRAIN TRIMMING COLOURS_

COL.40 BIANCO	COL.45 PERLA	COL.63 SENAPE	COL.84 ROSSO
COL.83 ARANCIO	COL.65 RUBINO	COL.93 PRUGNA	COL.159 VINO

COL.91 MELANZANA	COL.157 VIOLA	COL.154 MOSTO	COL.124 SALVIA	COL.125 OLIVA	COL.136 SABBIA	COL.126 KAKI	COL.168 CASTORO	COL.97 CIOCCOLATO
COL.111 COBALTO	COL.104 ORIZZONTI	COL.173 AVIO	COL.116 OCEANO	COL.133 PRATERIA	COL.175 MUSCHIO	COL.51 ATMOSFERA	COL.101 CAFFÈ	COL.41 NERO

CORUS_

DESIGN R&S_ META DESIGN_

La tradizione non si dimentica mai in casa META DESIGN.
E' seguendo questo principio che è stato creato CORUS un modello dai meccanismi e le tecnologie sempre all'avanguardia che si fondono in linee e disegni che ricordano i tempi passati.

Tradition is never forgotten with META DESIGN.
CORUS has been created according to this concept: a model with state-of-the-art mechanisms and technology, combining lines with design that recall bygone days.

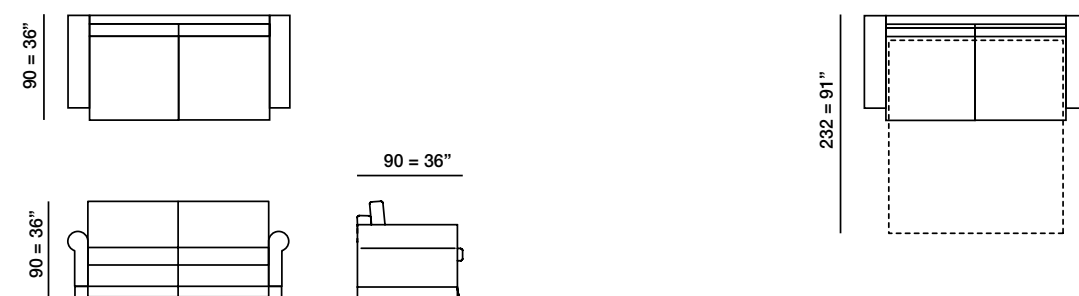



CORUS_





CORUS_

GIM_

DESIGN R&S_ META DESIGN_

GIM, il trasformabile per eccellenza dalle forme semplici e i meccanismi più all'avanguardia, unisce bellezza estetica alla praticità. La doppia funzionalità del divano-letto con materassi a partire da 200 cm e la vasta modularità, garantisce il massimo comfort per la convivialità e il riposo.

GIM is the pre-eminently sofabled with simple lines and with the most advanced mechanism, it combines beauty, esthetics and functionality.

The double function of the sofabled with mattresses 200 cm length and its extensive modularity is a guarantee of great comfort for socializing and for resting as well.

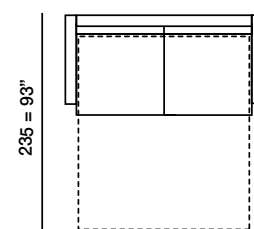
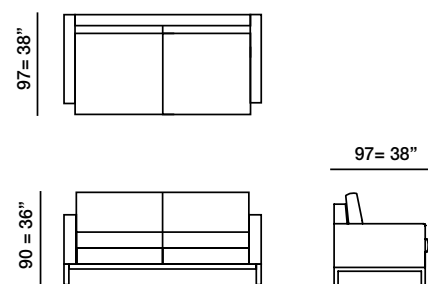





GIML





TOKYO_

DESIGN R&S_ META DESIGN_

L'oscar al miglior protagonista dei momenti conviviali della giornata va a TOKYO. Il divano e divano letto ideato per dominare la scena e catturare le attenzioni al centro della stanza. Schienali autoportanti e mobili che si posizionano liberamente in ogni punto della seduta, garantiscono sempre il giusto comfort. TOKYO si trasforma facilmente, per avere un divano e un letto ogni giorno diverso.

The Oscar for the best protagonist of the convivial moments of the day goes to TOKYO. The sofa and sofa bed designed to dominate the scene and capture the attention in the center of the room. Self-supporting and movable backrests that can be positioned freely at any point of the seat, always guarantee the right comfort. TOKYO can easily change, to have a sofa and a bed different every day.

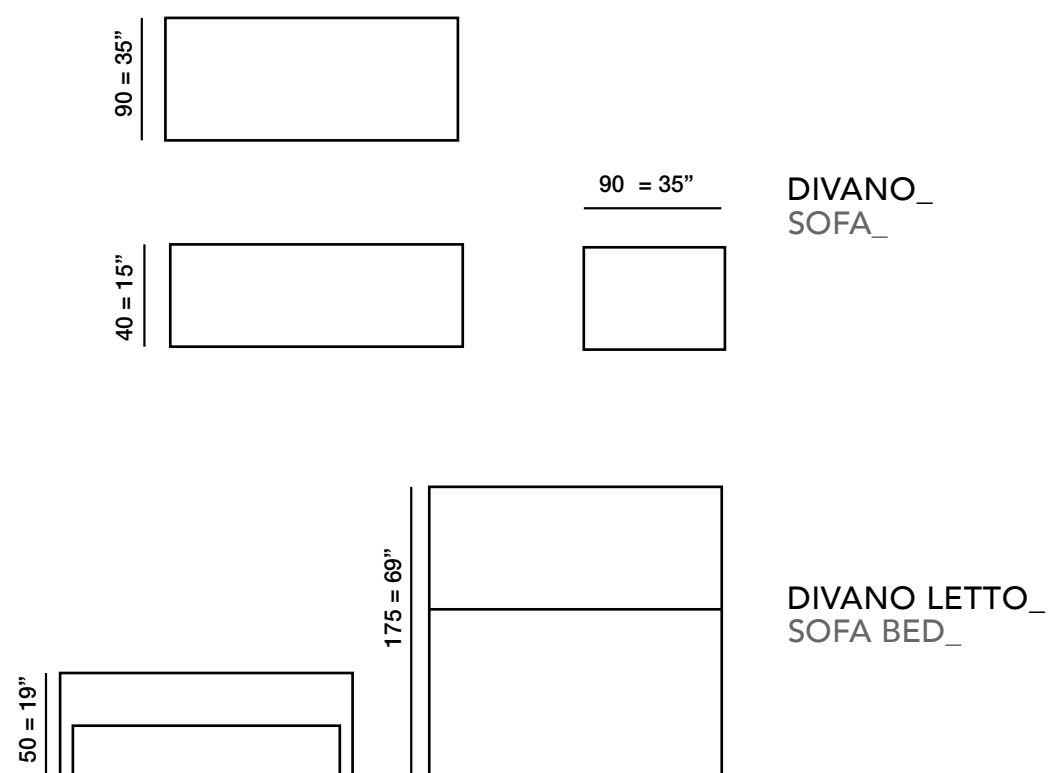





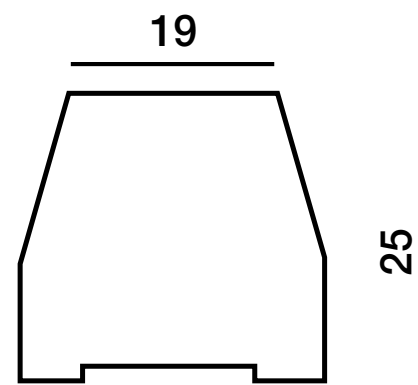

TOKYO_

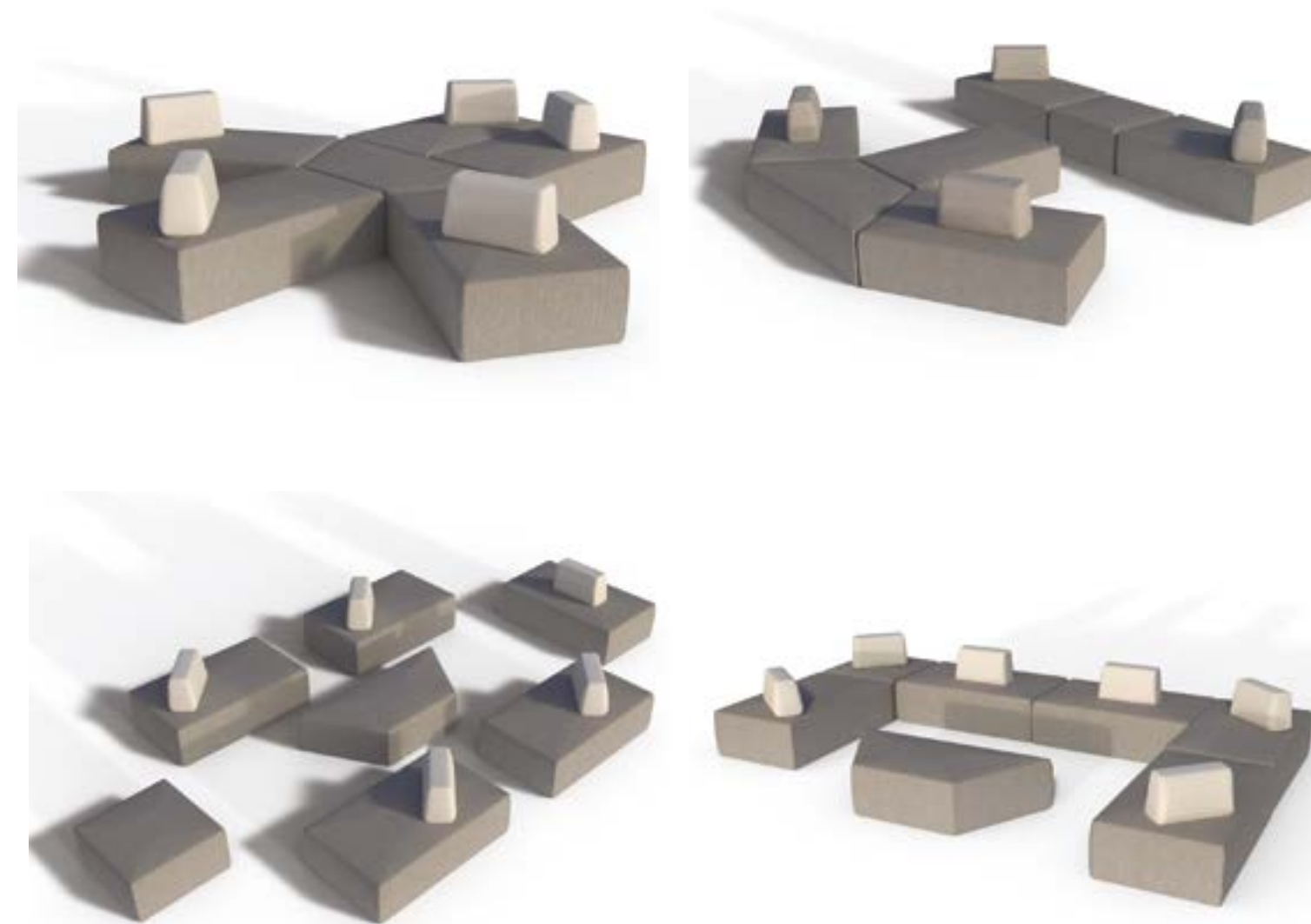

COLORE PROFILO GROS GRAIN_
GROS GRAIN TRIMMING COLOURS_

			
COL.40 BIANCO	COL.45 PERLA	COL.63 SENAPE	COL.84 ROSSO
			
COL.83 ARANCIO	COL.65 RUBINO	COL.93 PRUGNA	COL.159 VINO

								
COL.91 MELANZANA	COL.157 VIOLA	COL.154 MOSTO	COL.124 SALVIA	COL.125 OLIVA	COL.136 SABBIA	COL.126 KAKI	COL.168 CASTORO	COL.97 CIOCCOLATO
								
COL.111 COBALTO	COL.104 ORIZZONTI	COL.173 AVIO	COL.116 OCEANO	COL.133 PRATERIA	COL.175 MUSCHIO	COL.51 ATMOSFERA	COL.101 CAFFÈ	COL.41 NERO

MAGÒ_

DESIGN R&S_ META DESIGN_

MAGO' un vero trasformista. Divanetto a tre posti, letto singolo e secondo letto singolo sottostante che si può estrarre e alzare. Insomma un sistema semplice ma articolato che trova più utilizzi a seconda delle esigenze. Un prodotto che ben si colloca negli appartamenti attuali dove gli spazi devono essere gestiti con sapienza gusto e attenzione al design.

MAGO' is a real transformer. A three place seater, single bed and an underneath second single bed which is extractable and can be lifted. An easy system but elaborate which has different use according to ones needs. A product which can be easily placed in today's flats where space is administered with knowledgeable taste and with attention to the design.

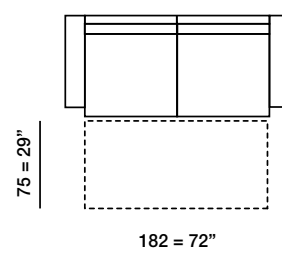
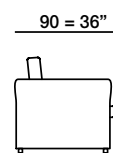
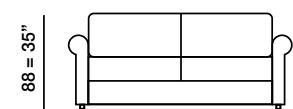
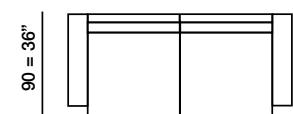





MULTI_

DESIGN R&S_ META DESIGN_

Lo dice la parola, MULTI funzione: divano, letto, contenitore etc..
Linea estremamente versatile, modulare e completa. Offre mille soluzioni pratiche senza rinunciare al design e all'eleganza. Adatto a spazi grandi e piccoli, e dove si vuole percepire e vedere il comfort. Volumetrie dolci e sinuose.

The meaning is in the word , MULTI functions: couch, bed, container etc..
extremely versatile modular and complete. It offers many practical solutions without sacrificing design and elegance. Suitable for large and small spaces, and where you perceive and see the comfort. Soft, sinuous volumes.

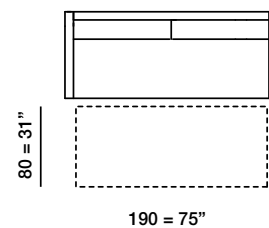
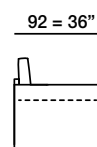
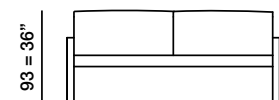
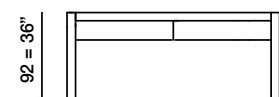





MULTI





BRACCIOLO A_
ARMREST A



BRACCIOLO B_
ARMREST B



COLORE PROFILO GROS GRAIN_
GROS GRAIN TRIMMING COLOURS_

COL.40 BIANCO	COL.45 PERLA	COL.63 SENAPE	COL.84 ROSSO
COL.83 ARANCIO	COL.65 RUBINO	COL.93 PRUGNA	COL.159 VINO

COL.91 MELANZANA	COL.157 VIOLA	COL.154 MOSTO	COL.124 SALVIA	COL.125 OLIVA	COL.136 SABBIA	COL.126 KAKI	COL.168 CASTORO	COL.97 CIOCCOLATO
COL.111 COBALTO	COL.104 ORIZZONTI	COL.173 AVIO	COL.116 OCEANO	COL.133 PRATERIA	COL.175 MUSCHIO	COL.51 ATMOSFERA	COL.101 CAFFÈ	COL.41 NERO

OLIMPUS_

DESIGN R&S_ META DESIGN_

Eleganza esclusiva dedicata agli amanti del benessere. Bellezza unita a funzionalità in una linea accogliente. Maestoso ed imponente è OLIMPUS. Ideale per un utilizzo quotidiano, questo modello, con un semplice movimento si trasforma da letto in comodo divano, contenendo al suo interno lenzuola, coperta e guanciali. OLIMPUS, da oggi, si potrà avere, su richiesta, con la versione motorizzata. Con un telecomando e quindi con un semplice gesto, il divano letto si aprirà e chiuderà da solo.

Exclusive elegance for those who love wellbeing. Beauty combined with practicability for an attractive collection. OLIMPUS, is majestic and attractive. Ideal for day-to-day use, with a simple gesture this model turns from a bed into a comfortable sofa, while storing sheets blankets and pillows inside. Starting from today OLIMPUS, may be produced, upon request, with motorized version. Thanks to a remote control, with a very simple act, the sofa bed will open and close by itself.



VIDEO DEL MECCANISMO ELETTRICO_
VIDEO FOR ELECTRICAL MECHANISM

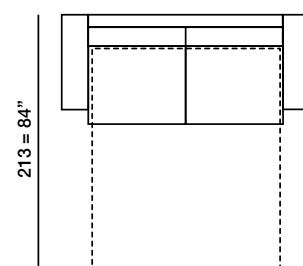
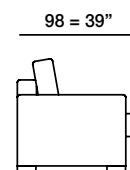
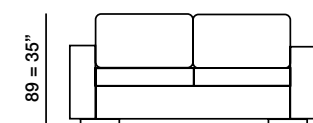
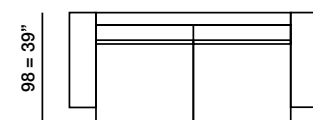





BRACCIOLO A_
ARMREST A



BRACCIOLO B_
ARMREST B



BRACCIOLO L_
ARMREST L





ROMEO_

DESIGN R&S_ META DESIGN_

Il trasformabile ROMEO nasce con un ottimo meccanismo che permette di realizzare il letto senza spostare alcun cuscino.
Linearità preziosa, rigore formale funzionalità razionale, descrivono alla perfezione questa collezione.

ROMEO convertible sofa comes with an excellent mechanism that allows you to make the bed without removing any cushions.
Precious linearity, formal rigor, rational functionality, describe this collection to perfection.

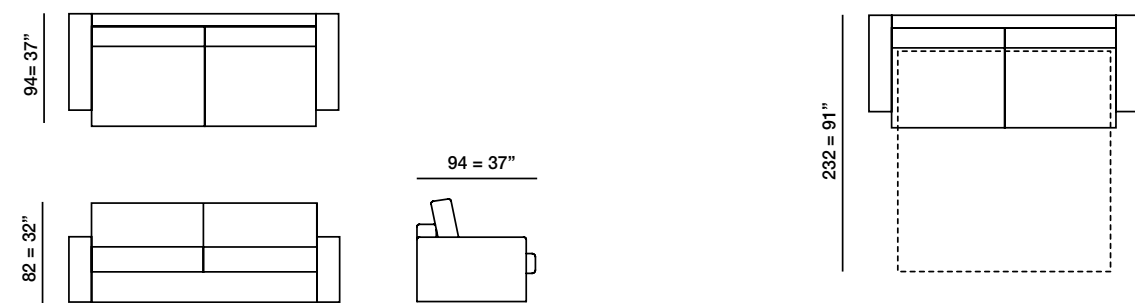



BRACCIOLO AR_
ARMREST AR



BRACCIOLO A_
ARMREST A



BRACCIOLO L_
ARMREST L



BRACCIOLO B_
ARMREST B





ROMEO

SUPER_

DESIGN R&S_ META DESIGN_

"SUPER" è un divano letto che offre un ottimo comfort nella posizione letto ed è altrettanto confortevole come divano. Inoltre offre una penisola contenitore ed uno schienale con vano porta cuscini.

SUPER offers a great comfort as a bed and it is likewise comfortable as a sofa. Furthermore it has a great chaiselongue which has a storing space underneath and a back with space for your pillows.

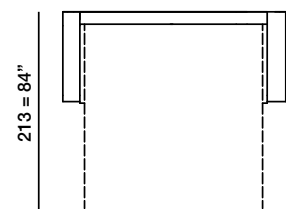
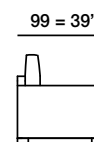
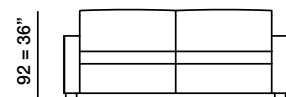
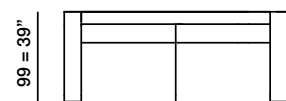



BRACCIOLO A_
ARMREST A



BRACCIOLO B_
ARMREST B



BRACCIOLO C_
ARMREST C



BRACCIOLO D_
ARMREST D



BRACCIOLO E_
ARMREST E





SUPER

POUF LAMPO_

DESIGN R&S_ META DESIGN_

POUF LAMPO è l'elemento più sorprendente di tutta la nostra collezione. Un piccolo elemento che racchiude in se tutta la comodità di un confortevole letto per gli ospiti. Rivestibile nelle stesse finiture dei nostri divani è l'elemento indispensabile per chi vuole trasformare la praticità di un indispensabile elemento imbottito nell'indispensabile utilità di un comodo letto in più.

POUF LAMPO is the most surprising element of our entire collection. A small element that contains all the convenience of a comfortable guest bed. Upholstered in the same finishes as our sofas, it is the indispensable element for those who want to transform the practicality of an indispensable upholstered element into the indispensable utility of an extra comfortable bed.

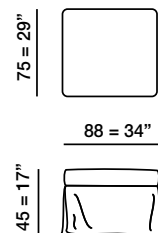



LA NOSTRA MOLTEPLICITÀ OUR UNICA_ UNIQUE MULTIPLEICITY_

POLTRONE
ARMCHAIRS

PRODOTTI META DESIGN

nascono dalla riflessione sui desideri che ci spingono a vivere in modo meno formale e a reinventare spazi e funzioni. Ricerca di linee sobrie e informali, leggere e dinamiche. Design calibrato che unisce ergonomia e comfort. Light, etnico, classico, moderno, la libertà di scegliere il tuo stile

META DESIGN'S PRODUCTS

are conceived by the aspirations to live less formally and the best way to reinvent spaces and functions. The search of simple lines, informal light and dynamic. Balanced design which combines ergonomics and comfort. Light, ethnic, classic, modern the freedom to choose your style.

LUCIA_

DESIGN R&S_ META DESIGN_

LUCIA è un portale verso un passato presente. Una poltroncina con un design sinuoso ed avvolgente e offre all'utilizzatore un comfort unico.

LUCIA represents a past present. An armchair with a sinuous and enveloping design and offers the user unique comfort.

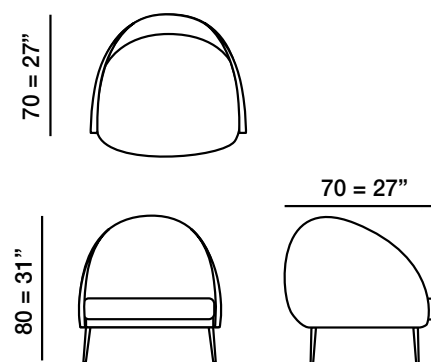

SHEDIR_

DESIGN R&S_ META DESIGN_

Riposo e comodità sono sinonimo di SHEDIR, una poltrona dalla seduta lunga e accogliente e dalle finiture raffinate e misurate. L'accessorio perfetto di ogni salotto e camera da letto.

Rest and comfort are synonymous with SHEDIR, an armchair with a long and enveloping seat and refined finishes. The perfect accessory for any living room and bedroom.

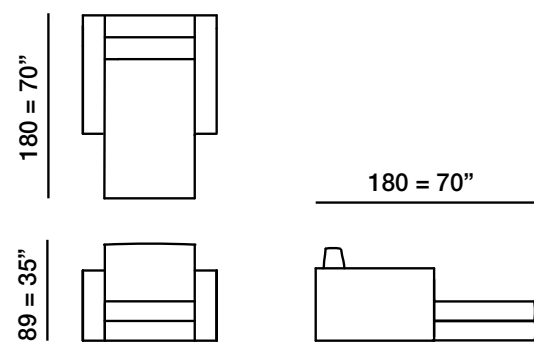



SHEDIR_

STRADIVARI_

DESIGN R&S_ META DESIGN_

Sinonimo di eleganza e portamento, STRADIVARI è pensata per inserirsi nella scena con discrezione e incisività. Le linee armoniche disegnate dal taglio a vivo nei rivestimenti in pelle e le note vellutate danno alla seduta semicircolare il prestigio di una sinfonia avvolgente.

Synonymous of elegance and posture, STRADIVARI is designed to fit into the scene with discretion and incisiveness. The harmonic lines and the velvety notes designed by the raw cut of the leather give the semicircular seat the prestige of an enveloping symphony.

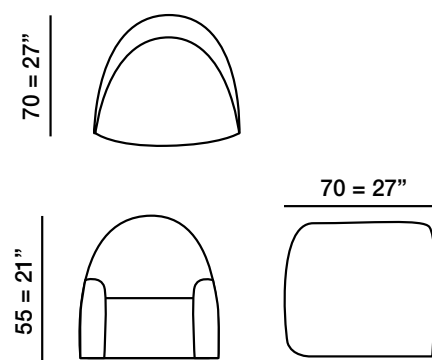

COLORADO_

DESIGN R&S_ META DESIGN_

Uno spazio personale in cui abbandonarsi al relax. Pensata per la zona giorno ma ideale per tutti gli ambienti della casa votati al comfort. COLORADO, un poltrona di design che rappresenta la perfetta unione tra volumi pieni e imbottiture morbide per una seduta avvolgente.

A personal space in which to indulge in relaxation. Designed for the living area but ideal for all rooms in the house devoted to comfort. COLORADO, a design armchair that represents the perfect union between full volumes and soft padding for an enveloping seat.

PERSONALIZZA IL BASAMENTO
CON QUALSIASI COLORE RAL.

PERSONALISE THE METAL STRUCTURE
WITH ANY RAL COLOUR.

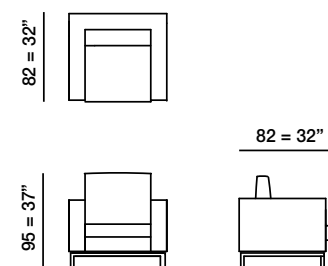

CLASSIC_

DESIGN R&S_ META DESIGN_

Il nome già dice tutto. CLASSIC è design che supera la prova estetica del tempo. Poltrona dalle forme arrotondatee da linee curve. Il comfort è dato da un cuscino di seduta in piuma.

The name says it all. CLASSIC design that goes beyond the aesthetic time test. This armchair has rounded shape and curved lines. The comfort is assured thanks to the leather sitting cushion.

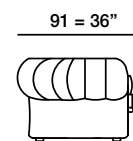
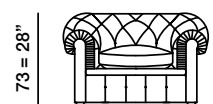
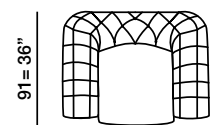

MARIAN_

DESIGN R&S_ META DESIGN_

L'apparente austerità di questa poltrona non deve ingannare:
è un ironico alternarsi di linee diritte e curve di grande attualità.
MARIAN si apprezza, per il suo straordinario comfort.

The apparent austerity of this armchair should not fool anyone.
There is an alternation of straight and curved lines, which is fiercely modern.
MARIAN can be appreciated, for its extraordinary comfort.

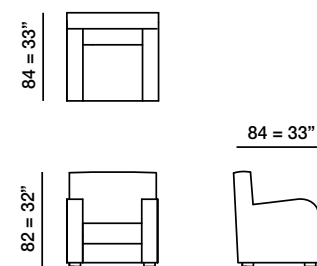



MARIAN

OPERA_

DESIGN R&S_ META DESIGN_

OPERA, lo dice la parola stessa, questa poltrona è una opera dolce e melodiosa. Una linea moderna e classica nel contempo, dove prevalgono le forme arrotondate e curve. Linee che accompagnano e migliorano il nostro comfort ed accentuano in modo gradevole l'aspetto ergonomico, disponibile anche nella versione girevole.

OPERA, the word itself says that this armchair is a sweet and melodious opera. A modern and classic line at the same time, where rounded and curved shapes prevail. Lines that accompany and improve our comfort and pleasantly accentuate the ergonomic features. Available also in the swivel version.

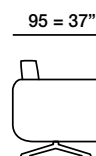
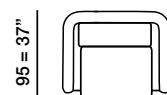

SINFONIA_

DESIGN R&S_ META DESIGN_

La poltrona SINFONIA, unisce volumi compatti e ben equilibrati per ridurre al minimo gli ingombri con una seduta molto accogliente e confortevole. SINFONIA è stata studiata per spazi piccoli e per donare un tocco di design.

SINFONIA armchair combines compact and well-balanced volumes to reduce the overall dimensions to a minimum with a very welcoming and comfortable seat. SINFONIA has been designed for small spaces and to give a touch of design.

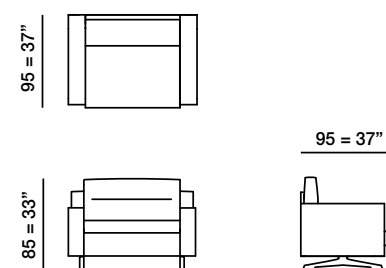

LETTI META DESIGN

I nostri letti, imbottiti sofficemente, in tessuti od in pelle sono il risultato di uno studio del mercato e delle sue esigenze. La collezione letti, è nata con l'obbiettivo di migliorare il comfort, il benessere e la qualità della vita. Oggi produciamo oltre 30 modelli di letti, da scegliere a misura del proprio gusto e della proprie esigenze, che spaziano dai singoli ai matrimoniali, sollevati da terra, con box e senza box. I meccanismi per il sollevamento, da noi utilizzati, sono 100% made in Italy e della migliore qualità. Una novità assoluta è il meccanismo per reti motorizzate con possibilità di spazio contenitore.

META DESIGN'S BEDS

Our beds, softly upholstered in fabric or leather are the result of a market research and its needs. The collection beds, was studied with the goal to improve the comfort, well-being and quality of life. Today we produce over 30 models of beds, to be chosen according to one's own taste and needs. Ranging from single to double, off the ground, with and without storing space. The lifting mechanisms we use are 100% made in Italy and of the best quality. An absolute innovation is the mechanism for motorized networks with storing space.

LETTI
BEDS

**LA NOSTRA
MOLTEPLICITÀ
OUR UNICA_
UNIQUE
MULTIPLEICITY_**

FLY LIGHT_

DESIGN R&S_ META DESIGN_

Un battito d'ali, un volo d'uccello...il gruppo notte FLY con i suoi delicati profili si stacca dal suolo con linee aerodinamiche che ricordano le ali degli uccelli.

A bird's wing flapping a bird's flight...FLY the night system with lines which are a reminder of the bird's wings.

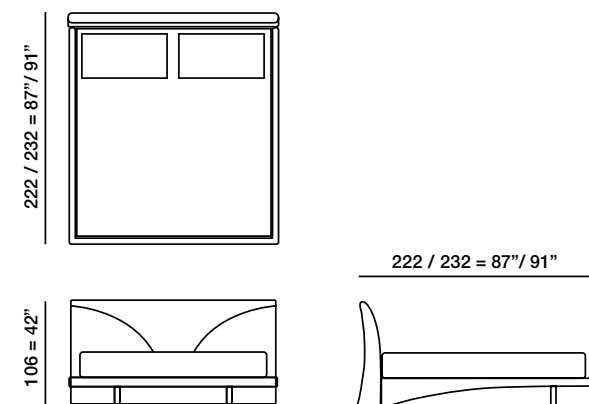





JOJOBA_

DESIGN R&S_ META DESIGN_

Capace di offrire delle sorprendenti soluzioni per la camera da letto, JOJOBA rappresenta una nuova frontiera per l'arredamento sia in ambienti domestici che in quelli alberghieri. La possibilità di applicare sulla stessa panca sia un letto matrimoniale che due letti singoli è la soluzione ideale a problemi di spazio JOJOBA è un sistema particolare che si compone di tre parti da assemblare liberamente, la panca, la testiera e la rete. La testiera è disponibile nelle versioni a rullo e a virgola. I piani laterali in vetro fungono da eleganti comodini salva spazio a cui si possono aggiungere dei led luminosi dalle luci estremamente rilassanti.

JOJOBA offers surprising solutions for the bedroom and is an innovative product for homes and hotel rooms alike. The same bench can be used in combination with a double bed as well as with two single beds, which is ideal whenever space is at a premium, especially in hotel rooms. JOJOBA is a special system that consist of three components to be assembled freely, a bench, a headboard and a bed base. The headboard is available in the "rullo" and "virgola" versions. You can also choose the bed versions without headboard. The side tops become practical space-saving bedside tables, which can be finished relaxing led lights.

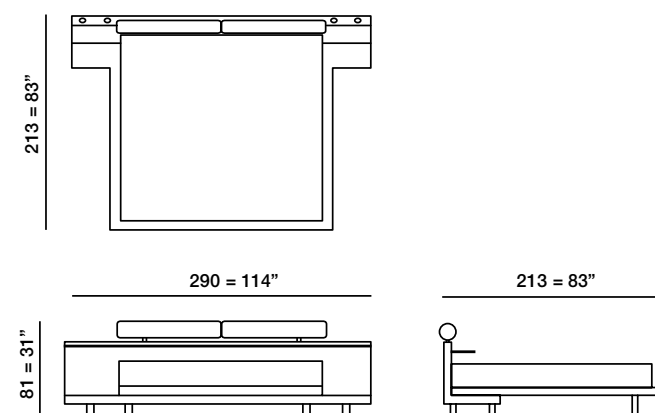





MISTRAL_

DESIGN R&S_ META DESIGN_

La sinuosità delle linee, l'estetica morbida e curvilinea sono pensate come metafora del riposo accogliente, del relax avvolgente. Un letto disegnato come simbolo di camera come luogo di affetto e protezione. Come un vento caldo che porta via tutto quello che non c'entra con il nostro mondo.

The sinuous lines, the soft, curved design are conceived as a metaphor for a cozy rest, and for an embracing relax. A bed designed as bedroom symbol as a place of warmth and protection. Like a warm wind that carries away everything that has nothing to do with our world.

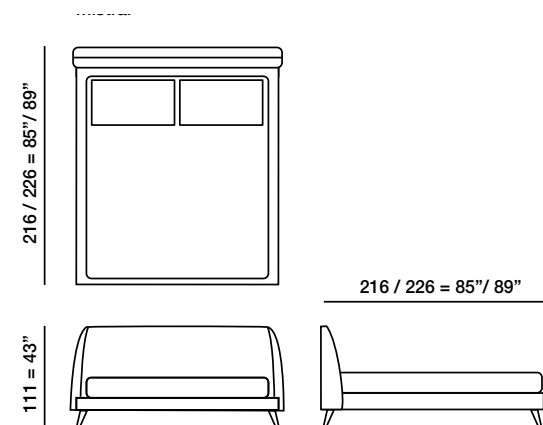



MISTRAL



MISTRAL

MONET_

DESIGN R&S_ META DESIGN_

Design moderno, forme essenziali ideali per chi ama il minimalismo, MONET è stato studiato per quelle coppie che vogliono inserire nella propria camera un bel prodotto di alta riconoscibilità. Ideale anche nella versione singola per le camerette dei ragazzi.

Modern design, basic shapes ideal for lovers of minimalism design, MONET was designed for those couples who wish to furnish their bedroom with a beautiful product of high standards. This is also an ideal bed for children's bedroom.

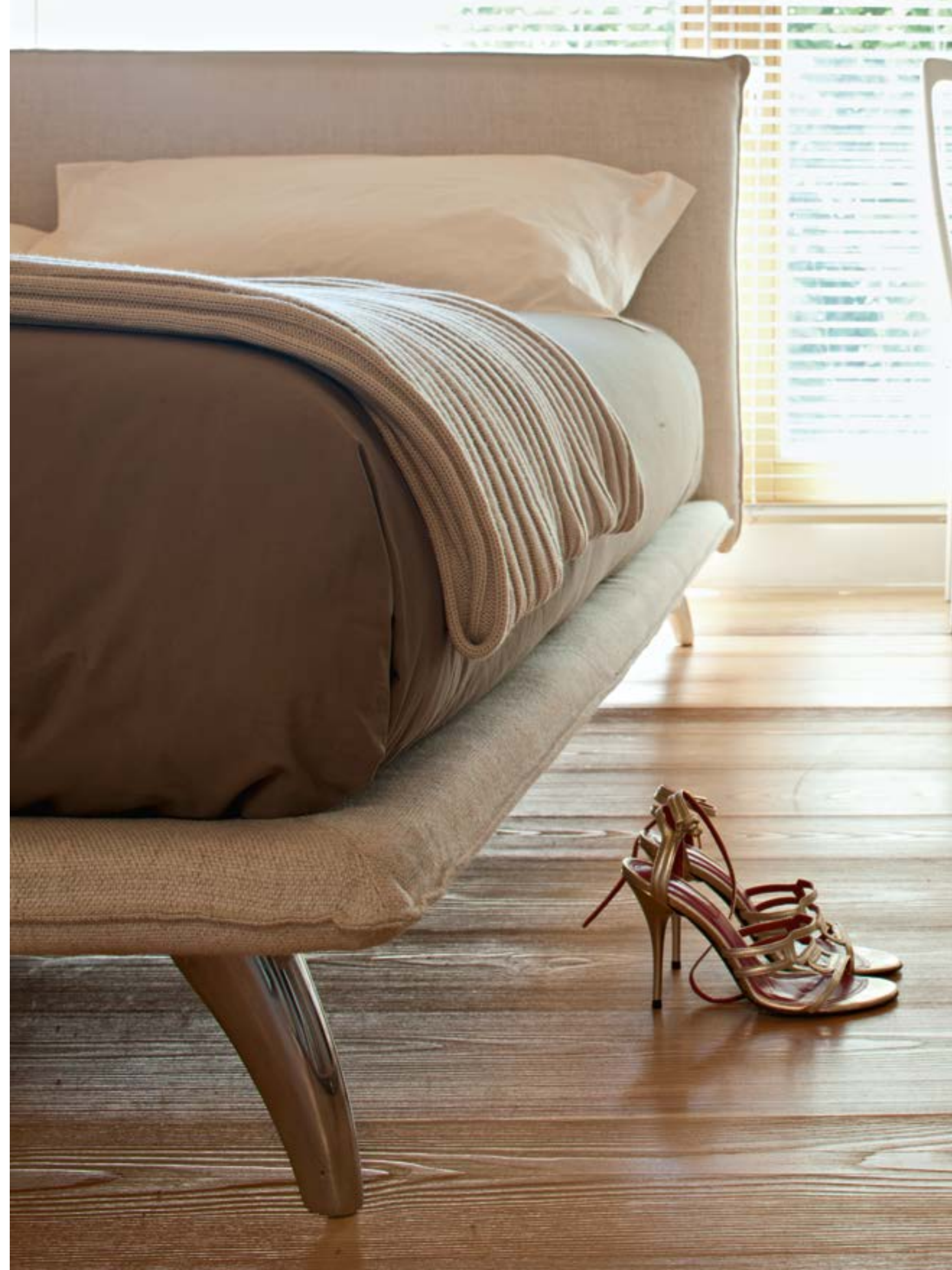
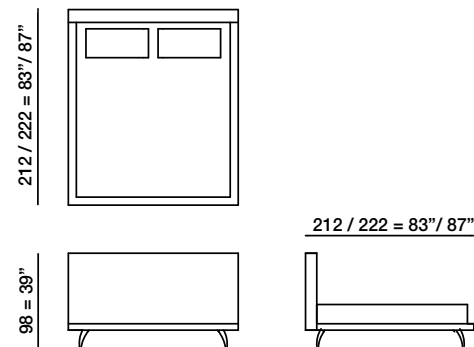

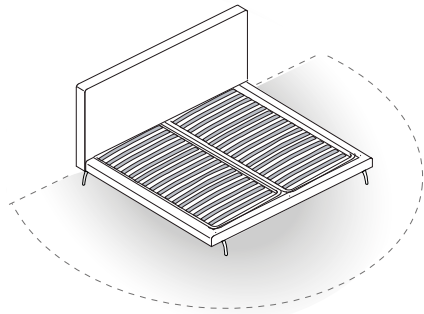

LUCE CON SENSORE DI PRESENZA
LIGHT WITH SENSOR OF PRESENCE



MONET PLUS_

DESIGN R&S_ META DESIGN_

È un letto dal design elegante e contemporaneo, caratterizzato dal tocco originale della testata imbottita a due cuscini, che dona al modello un carattere infinitamente accogliente.

It is a bed with an elegant and contemporary design, characterized by the original touch of the padded headboard with two cushions, which gives the model an infinitely welcoming character.

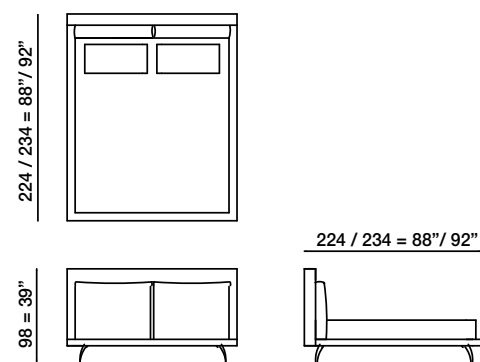

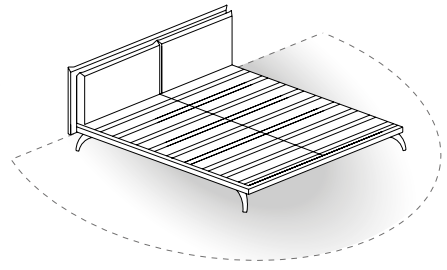

LUCE CON SENSORE DI PRESENZA
LIGHT WITH SENSOR OF PRESENCE



MONET PLUS

PARIDE_

DESIGN R&S_ META DESIGN_

Leggero, agile, alto: queste sono le sensazioni che trasmette questo letto.
PARIDE un letto progettato con maestria per assolvere ad esigenze pratiche di funzionalità ed estetica. Ricerca di tessuti nuovi per rispondere alle richieste di mercato e colori sempre nuovi e di tendenza.

Light, high, agile: these are the feelings that this bed conveys. PARIDE is a bed studied with skills to perform every day functional and esthetic needs. Research of new fabrics to reply to the markets request for always new colors and trend.

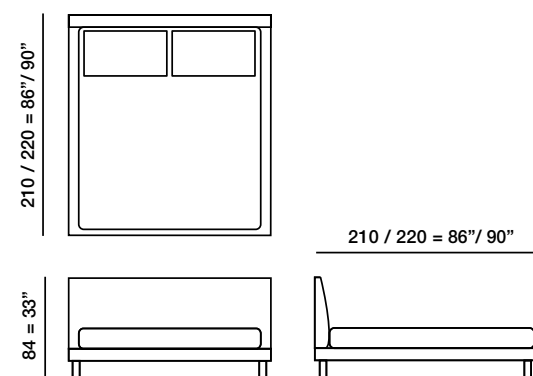

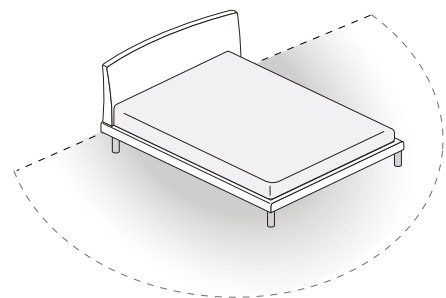

LUCE CON SENSORE DI PRESENZA
LIGHT WITH SENSOR OF PRESENCE



PARIDE

CRYSTAL_

DESIGN R&S_ META DESIGN_

Letto dal grande impatto visivo, con una testiera a fasce verticali imbottite e lavorate individualmente con grande artigianalità. Un design unico nel suo genere, che lo rende immediatamente riconoscibile ma anche spiccatamente unico. Il giroletto minimalista di stile moderno è la firma di CRYSTAL.

Bed with a great visual impact, with a headboard with vertical padded bands and individually worked with great craftsmanship. A unique design of its kind, which makes it immediately recognizable but also distinctly unique. The minimalist modern style bed frame is CRYSTAL's signature.

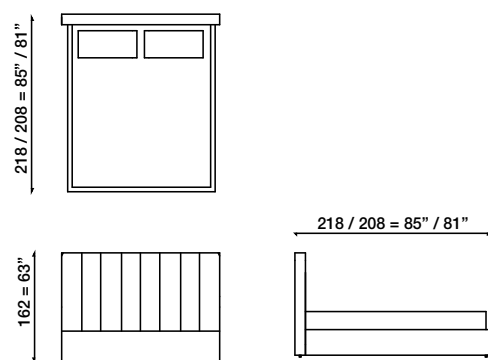



CRYSTAL

BOSS_

DESIGN R&S_ META DESIGN_

Il concetto di letto imbottito nella sua massima espressione.
BOSS, idealmente semplice nelle sue linee costruttive, ma assolutamente ricco internamente grazie alla piuma rende il giroletto e gli ampi cuscini testiera ancor più morbidi.

The concept of a padded bed at the highest level.
BOSS perfectly simple in its construction lines, but its feather filling, which makes the bed ring and the wide cushions headboard even softer looking.

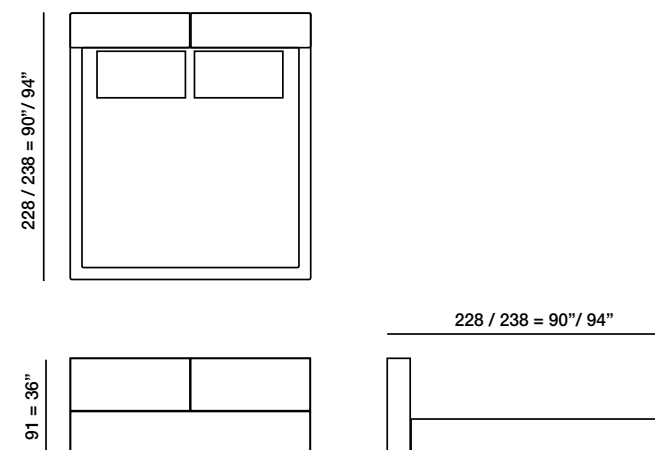



BOSS_





BOSS_



BOSS_

PRINCE_

DESIGN R&S_ META DESIGN_

Forme sinuose e molto morbide sono la caratteristica principale del letto PRINCE, che grazie alla soffice imbottitura della testiera, è in grado di donare il massimo comfort a coloro che lo sceglieranno per la propria casa.

PRINCE bed main features are the very soft and sinuous shapes. Thanks to the headboard's very soft padding, it offers, to those who will chose this bed for their own house, the greatest comfort.

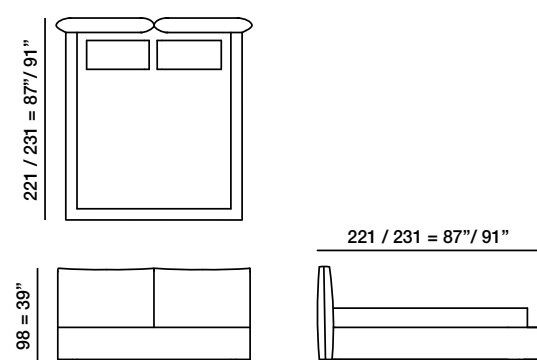



PRINCE_

ANTHEA_

DESIGN R&S_ META DESIGN_

ANTHEA è l'elemento ideale per dare un tocco di eleganza e charme a uno spazio dedicato al relax e al benessere personale. Un letto imbottito con bordino, dalla forma dolce e sinuosa. Un design che parte dai toni moderni per affondare in quelli più spiccatamente contemporanei. Il giroletto, morbido e arrotondato, è ergonomico e funzionale al tempo stesso.

ANTHEA is the ideal element to give a touch of elegance and charm to a space dedicated to relaxation and personal well-being. An upholstered bed with a piping, with a soft and sinuous shape. A design that starts from modern tones to sink into the more distinctly contemporary ones. The soft and rounded bed frame is ergonomic and functional at the same time.

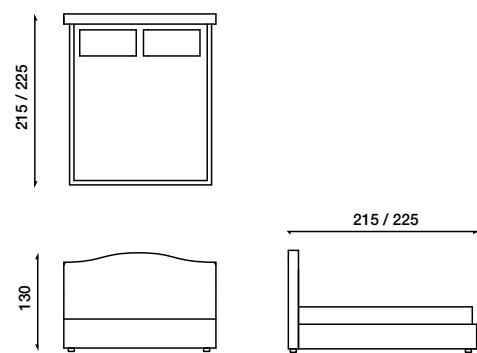



ANTHEA

KING_

DESIGN R&S_ META DESIGN_

Il letto KING è dedicato ad una clientela giovane dai gusti moderni, che ama le linee morbide, i colori naturali, e che vuole fare del proprio letto il protagonista della stanza.

KING bed is dedicated to young people who love contemporary, soft lines, natural colors and for those who want the bed to be the protagonist of the room.

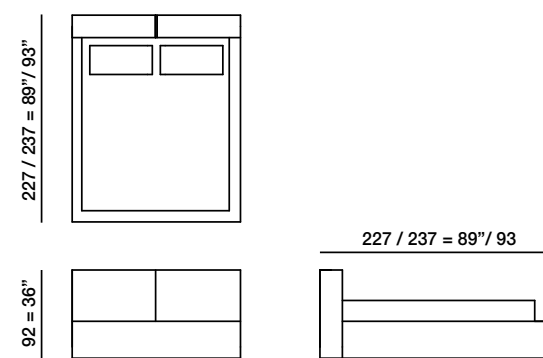



KING_



KING_

ARIA_

DESIGN R&S_ META DESIGN_

Soffia ARIA di sintesi stilistica. Le geometrie dimensionali, infatti, scelgono un'espressività moderna, con una testiera elevata e avvolgente. Ma le trame dei tessuti citano una signorilità, evocativa di epoche raffinate, in cui le camere da letto seguivano stilemi altamente signorili. Il bello del passato si fa presente.

ARIA is a blow of stylistic synthesis. The dimensional geometries, in fact, choosing modern expressiveness, with a high and enveloping headboard. Nevertheless, the fabric textures brings back an evocative elegance of refined eras, where the bedrooms represented highly noble styles. The beauty of the past becomes present.

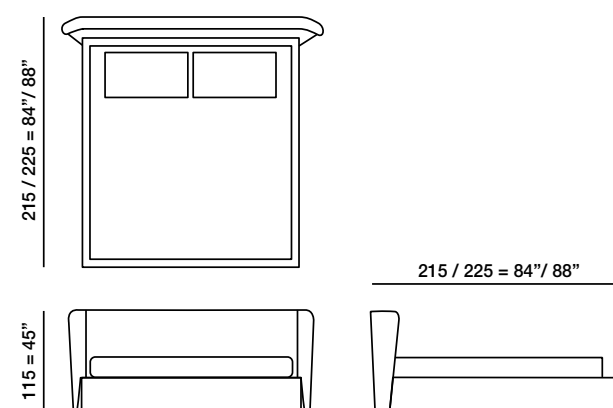



ARIA

NIVES_

DESIGN R&S_ META DESIGN_

NIVES è la tradizione arricchita di accenti contemporanei. Letto dalla struttura elegante e dall'estetica raffinata, viene dominato dal fascino e dal pregio della lavorazione capitonné, attualizzata e rigorosamente eseguita a mano. L'impuntura supera il classico schema a losanghe e segue un originale disegno asimmetrico, dallo stile informale e dinamico. Giroletto sommier, testiera imbottita e trapuntata.

NIVES is tradition enriched with contemporary accents. Bed with an elegant structure and refined aesthetics, it is dominated by the charm and value of the capitonné workmanship, updated and rigorously done by hand. The stitching goes beyond the classic diamond pattern and follows an original asymmetrical design, with an informal and dynamic style. Sommier bed frame, padded and quilted headboard.

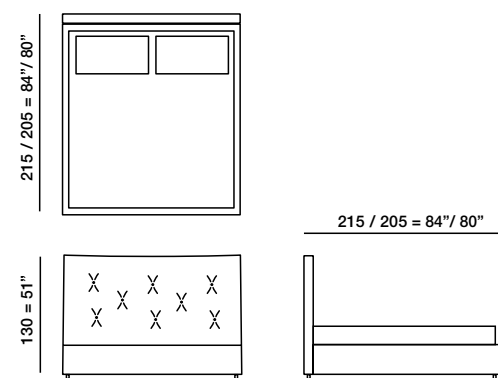



NIVES_

CLASS_

DESIGN R&S_ META DESIGN_

Il nome non è certo casuale: linee classiche ma pur sempre attuali. Si distingue per la caratteristica lavorazione capitonnée dell'alta testiera. Riproposta nella base giro letto, assieme alla versione liscia ed a quella con i bottoni. Arricchito ulteriormente dall'esclusivo sistema di sollevamento ed apertura in due diverse versioni.

Its name is certainly not a coincidence: classic lines that remain up-to-date. Distinguished by its characteristic capitonnée working on the high bedhead. Which is also offered around the base of the bed, together with a smooth version and one with buttons. Further enriched by the exclusive lifting and opening system in two different versions.

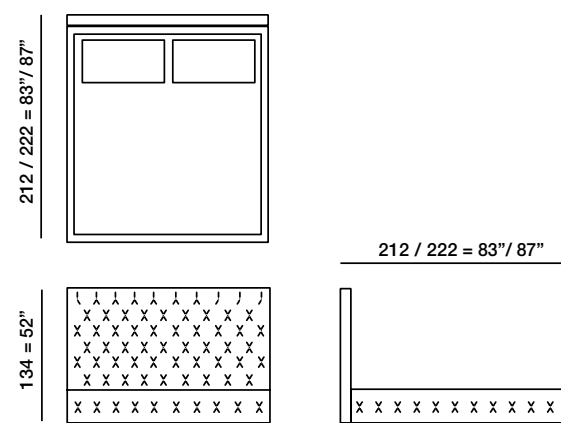



CLASS_





VERSIONE 1_ CAPITONNÉ
VERSION 1 CAPITONNÉ



VERSIONE 2_ BOTTONI
VERSION 2 BUTTONS



VERSIONE 3_ LISCIO
VERSION 3 PLAIN



DIAMANTE_

DESIGN R&S_ META DESIGN_

Il particolare decoro a "DIAMANTE" della testiera rende quasi magico questo sistema notte. La pelle viene lavorata con minuzia e sapienza per esaltare la qualità del prodotto. Il giroletto, sempre in pelle, diventa spazio contenitivo quando il materasso viene alzato.

The "DIAMOND" feature of the headboard almost makes This night concept magical. The leather is treated with great care and skill in order to enhance the quality of the product. The ring of the bed always in leather, becomes a storage space when the mattress is lifted.

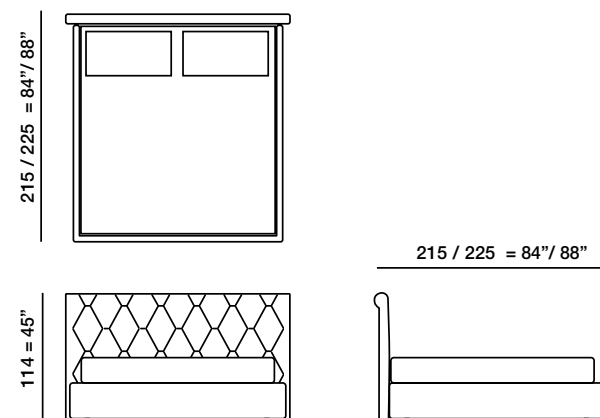





HYPNOS_

DESIGN R&S_ META DESIGN_

Letto letteralmente di alta personalità. La testiera, infatti, si staglia e si eleva netta, scenografica. Con la sua altezza, identifica l'insieme, conferendogli anche un senso simbolico di solidità, approdo, punto di riferimento per la notte e il riposo. Il resto della personalità è trasmesso dalle linee e trame elegantemente sofisticate.

Literally, bed of high personality. The headboard, in fact, stands out and rises clear in a scenographic way. With its height, it identifies the whole, also giving it a symbolic sense of solidity, landing place, reference point for the night and rest. The rest of the personality is conveyed by the elegantly sophisticated lines and textures.

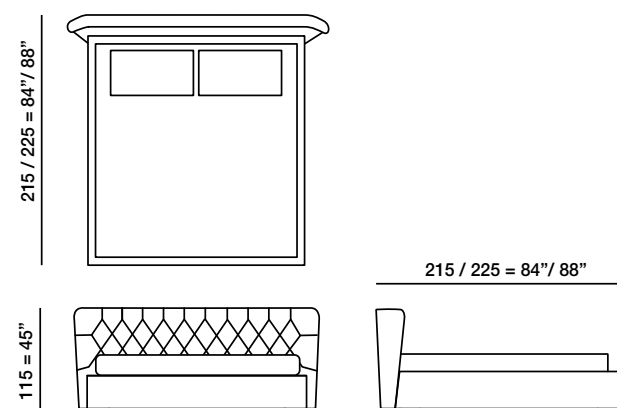





VENEZIA_

DESIGN R&S_ META DESIGN_

Linee morbide e arrotondate per un letto che evoca il passato ma anche la contemporaneità. VENEZIA esalta la bellezza del spazio notte. La lavorazione artigianale della testata, da un moderno capitonné realizzato con delicate cuciture che ne esaltano ancor più la valenza estetica di questo letto.

Soft, rounded lines for a bed that evokes the past but also the present. VENEZIA enhances the beauty of the night area. The handmade craftsmanship's, a modern tufted made with delicate stitching which adds further aesthetics to the bed.

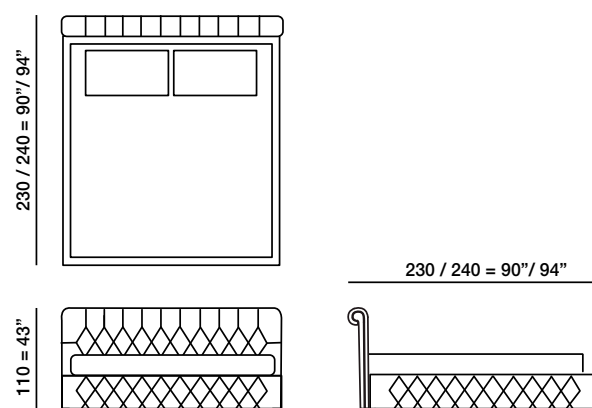





VERSIONE 1_ CAPITONÉ
VERSION 1 CAPITONNÉ



VERSIONE 2_ BOTTONI
VERSION 2 BUTTONS



VERSIONE 3_ LISCIO
VERSION 3 PLAIN



ALEX_

DESIGN R&S_ META DESIGN_

L'effetto trapuntato a con disegno a rombo esalta la lavorazione artigianale del letto ed enfatizza la morbidezza della testata. Un letto che arreda lo spazio con la sua grande presenza scenica.

The quilted effect with rhombus design enhances the craftsmanship of the bed and emphasizes the softness of the headboard. A bed that furnishes the space with its great stage presence.

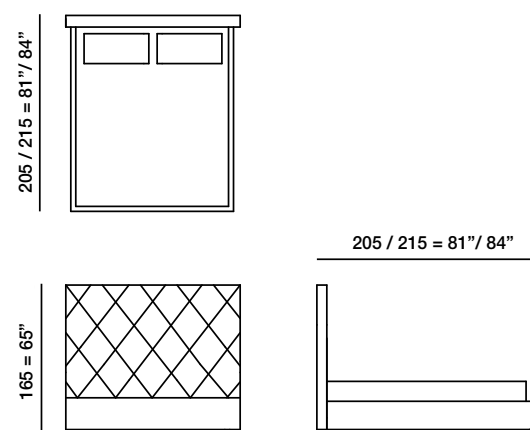



ALEX

FLY_

DESIGN R&S_ META DESIGN_

La sua forma dinamica permette di unire base e testiera in un unico volume slanciato, è una soluzione originale per un letto moderno. FLY è un letto imbottito e accogliente, si distingue per la forma futurista della testiera.

FLY è pensato per coloro che desiderano arredi di design originali per una camera moderna.

Its dynamic shape allows you to combine base and headboard in a single slender volume; it is an original solution for a modern bed. FLY is an upholstered and welcoming bed; it stands out for the futuristic shape of the headboard.

FLY is designed for those who want original design furnishings for a modern bedroom.

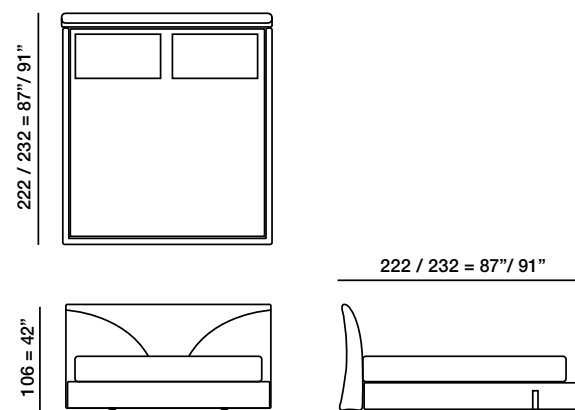





MENSOLA RIVESTITA CUIO OPTIONAL 1_
LEATHER UPHOLSTERED SIDE TABLES OPTIONAL 1



MENSOLA VETRO OPTIONAL 2_
GLASS SIDE TABLES OPTIONAL 2



MARIN_

DESIGN R&S_ META DESIGN_

C'è una parola che sintetizza tutto: sinuosità. Il design, infatti, disegna linee sinuose che arrotondano ogni particolare, completamente senza spigoli. Lo spazio si riempie così di una perfetta morbidezza estetica. Una morbidezza che ingloba principi ergonomici. Una bellezza plasmata sui nostri movimenti.

There is a word that sums it all up: sinuosity. The design, in fact, draws sinuous lines that round off every detail, completely without edges. The space is thus filled with a perfect aesthetic softness. A softness that incorporates ergonomic principles. A beauty molded on our movements.

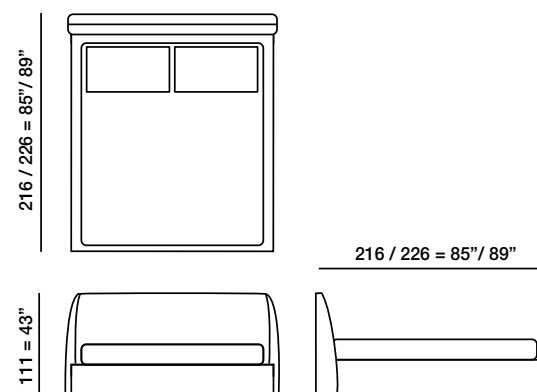



MARIN_

PIZZICO_

DESIGN R&S_ META DESIGN_

PIZZICO, il nome deriva dalla caratteristica pizzicatura della pelle e dei tessuti nella lavorazione della testiera. Il gioco della quadrettatura diventa tridimensionale, grazie a questa certolina cucitura. Il giroletto ben si inserisce in questo contesto in quanto prevede attente cuciture nei punti chiave. Anche questo sistema notte prevede un vano per gli oggetti sotto il materasso.

The name comes from the peculiar feature of the leather and fabric stitching in the headboard. The checkered head board becomes tridimensional, thanks to the accurate seams. The ring also in this context foresees careful seams in the main points. This night system foresees a storage space for the objects underneath the mattress.

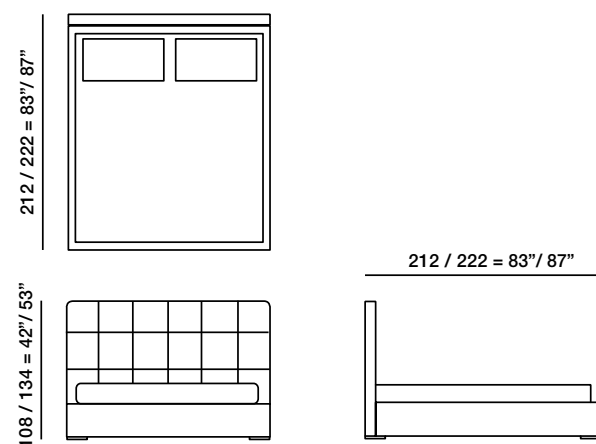



TOWER_

DESIGN R&S_ META DESIGN_

Davvero un letto d'arredamento: testiera con lavorazione pizzicata, incorniciata da una fascia di spessore, base sporgente, piedini a cipolla o in acciaio, finiture d'alto artigianato. Un vero protagonista nella zona notte.

Truly a bed which furnishes: a bedhead with a gathered finishing, framed by a wide band, with a prominent base, and onion or stainless steel feet and high quality craftsmanship finishings. A key player in the bedroom.

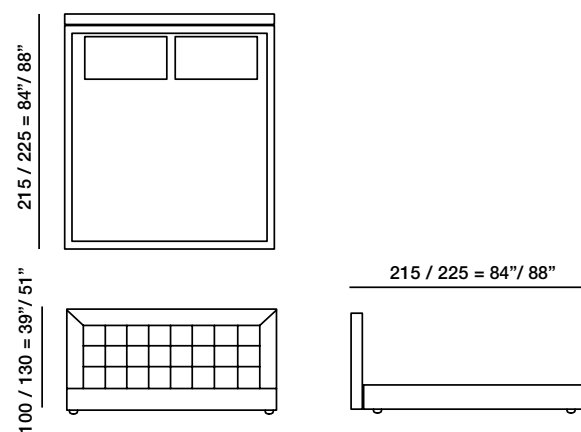



CENTAUREA_

DESIGN R&S_ META DESIGN_

Inondare di una luce moderna un ambiente dal gusto tradizionale:
è questo che rende speciale CENTAUREA, con le sue linee rilassanti e le preziose finiture.
I materiali, i dettagli, i particolari costruttivi danno forza al prodotto. Un oggetto senza
tempo, sempre attuale per le esigenze del vivere moderno.

A traditional environment is filled with light, this is what makes CENTAUREA so special,
with its relaxing lines and precious finishes. The materials, the details, the constructive
features give energy to the product. A timeless piece of furniture always up to date with
the needs of the modern living.

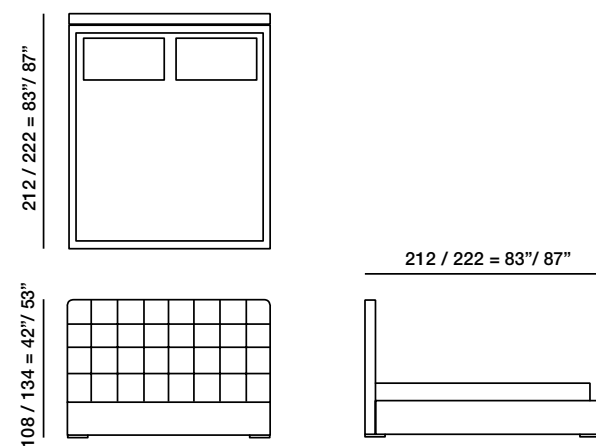





CLEOPATRA_

DESIGN R&S_ META DESIGN_

CLEOPATRA, un nome che evoca un grande passato, un sistema letto che non passa mai di moda. Comodo, confortevole e contestualizzabile in qualsiasi tipo di arredo.

CLEOPATRA, the name evokes a great past. A bed system which is an evergreen. Cozy, comfortable and it adapts to all types of furnishings.

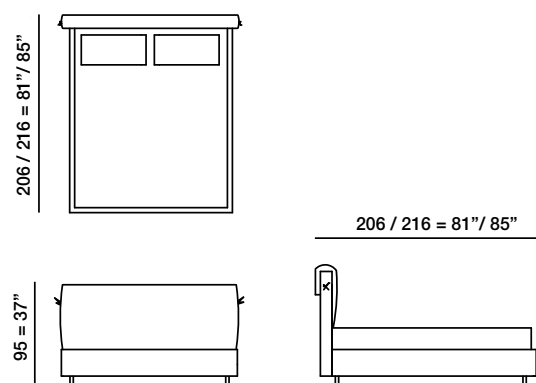

CLEOPATRA_



ARALDO_

DESIGN R&S_ META DESIGN_

Il benessere e il comfort assicurati dalla testata imbottita e arrotondata non sono l'unico plus del letto. Un design pulito e moderno lo rendono altrettanto unico.

The well-being and comfort ensured by the padded and rounded headboard are not the only plus of the bed. A clean and modern design make it equally unique

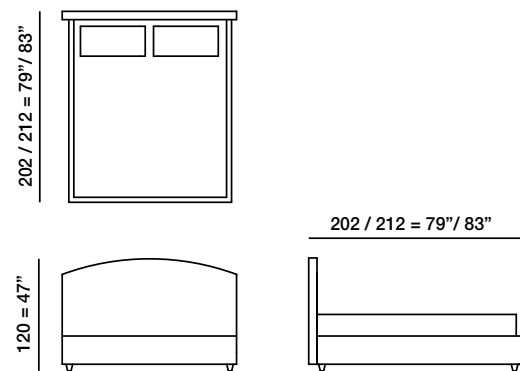



ARALDO_

IAGO_

DESIGN R&S_ META DESIGN_

Inondare di una luce moderna un ambiente dal gusto tradizionale: è questo che rende speciale Araldo, con le sue linee rilassanti e le preziose finiture.

The headboard has ergonomic padding in the upper part, which ensures maximum comfort for the body and gives the bed a minimal design.

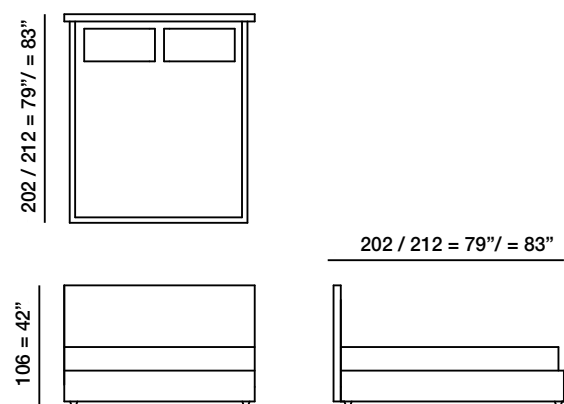



IAGO_

OLIVIERO_

DESIGN R&S_ META DESIGN_

Letto imbottito abbinabile ad una testiera a muro, ad un arazzo, a cuscini fissati alla parete oppure lasciato al centro della stanza per chi ha lo spazio. Rifinito su 4 lati e completamente sfoderabile.

Upholstered bed, which can be used with a wall headboard, with a tapestry, with cushions fixed to the wall. For whom has space It can be left in the middle of the room. Finished all around and completely removable

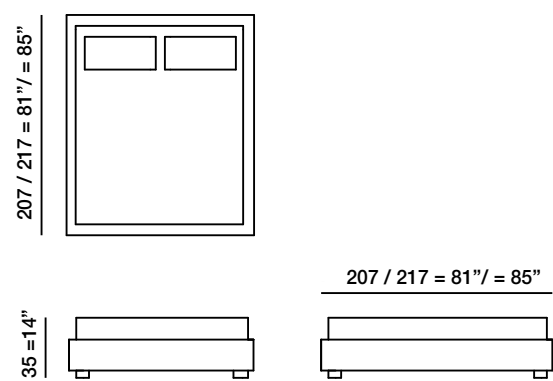



OLIVIERO_

OTTAVIO_

DESIGN R&S_ META DESIGN_

OTTAVIO in versione sommier è pensato per chi vuole personalizzare o decorare la parete dietro al letto o addirittura posizionarlo a centro stanza ma senza rinunciare a un pezzo di arredo dal design deciso e inconfondibile.

OTTAVIO in the sommier version is designed for those who want to personalize or decorate the wall behind the bed or even place it in the center of the room but without giving up a piece of furniture with a strong and unmistakable design.

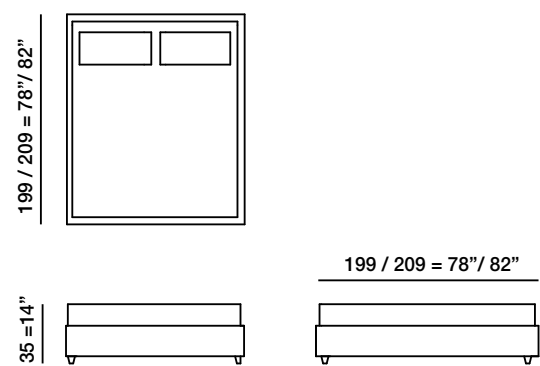



OTTAVIO

GIOTTO_

DESIGN R&S_ META DESIGN_

Il fascino e il segreto della forma tonda viene riproposta nel sistema notte GIOTTO. Forme particolari per soluzioni particolari. Il giroletto diventa anche veloce piano d'appoggio e la testiera si innesta ortogonalmente in questo grande disco di base imbottito. Materiali moderni e accuratezza dei dettagli conferiscono al sistema straordinaria originalità.

The charm and the secret of the round shape is proposed again in GIOTTO's night concept. Special shapes for distinguishing solutions. The ring of the bed becomes also a quick table top and the head board is connected orthogonally to the padded base. Modern materials and the accuracy of the details confer to the system an extraordinary originality.

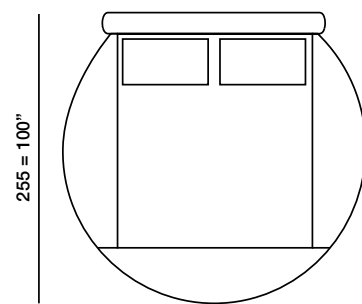
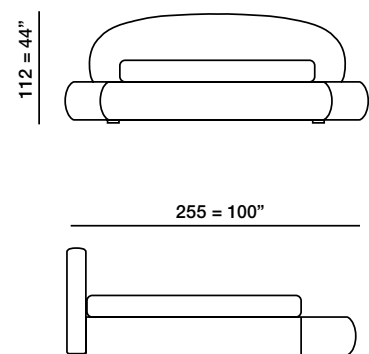





GIOTTO

GLOBE_

DESIGN R&S_ META DESIGN_

Il letto GLOBE è caratterizzato dall'originale testiera imbottita ad angolo volta ad ottimizzare gli spazi nella propria camera da letto. Si presenta dunque come una soluzione particolarmente originale e creativa per la zona notte.

The GLOBE bed's main feature is the original corner padded headboard aimed at optimizing the spaces in your bedroom. It therefore presents itself as a particularly original and creative solution for the area.

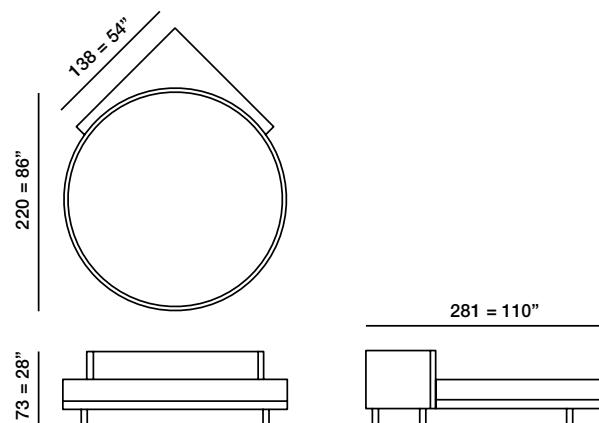

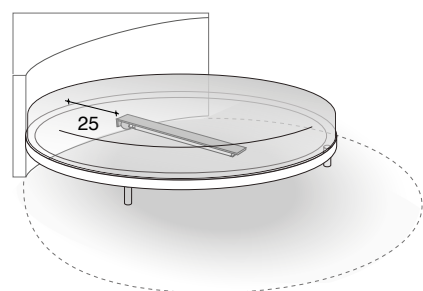

LUCE CON SENSORE DI PRESENZA
LIGHT WITH SENSOR OF PRESENCE



OTELLO_

DESIGN R&S_ META DESIGN_

Si ritrova la forma circolare anche nel materasso. Essenziale negli spessori e negli ingombri veste lo spazio in modo diverso e originale. La testiera circonda la composizione.

Here again the round shape and also in the mattress. Essential in the thickness and in the space it occupies furnishes the space in a different and original way. The fixed head board.

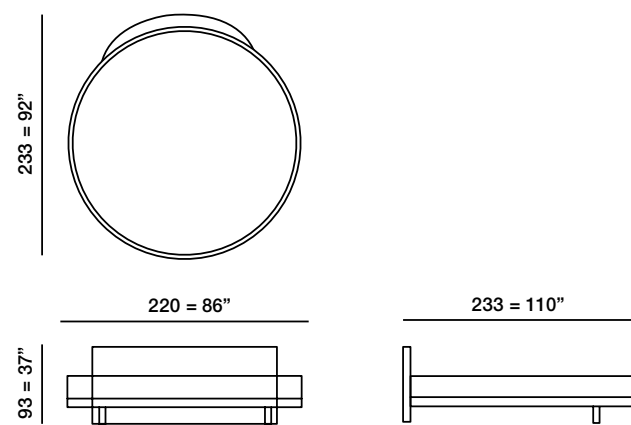

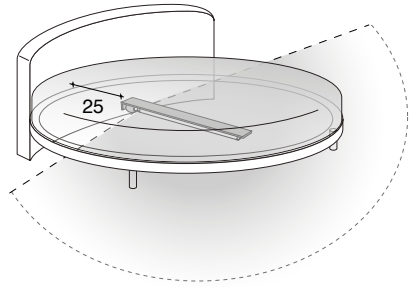

LUCE CON SENSORE DI PRESENZA
LIGHT WITH SENSOR OF PRESENCE



OTELLO

OTELLO LUXURY_

DESIGN R&S_ META DESIGN_

OTELLO, conosciuto e tradotto in tutte le lingue del mondo è uno dei pilastri della letteratura internazionale. Basato sul racconto del matrimonio in gran segreto tra OTELLO e Desdemona, ha ispirato i nostri designer che hanno dato vita all'omonimo letto OTELLO, rotondo, sontuoso e lussuoso. Finemente lavorato dalle sapienti mani degli artigiani che si tramandano di generazione in generazione la particolare lavorazione capitonnè, l'elemento di arredo diventa un'opera d'arte fatta della stessa arte e con la stessa poesia che si tramanda di generazione in generazione come la letteratura di OTELLO.

OTELLO, known and translated into all the languages of the world, is one of the pillars of international literature. Based on the story of the secret marriage between OTELLO and Desdemona, it inspired our designers who created the round, sumptuous and luxurious OTELLO bed with the same name. Finely worked by the skilled hands of the craftsmen who passed on the particular capitonné workmanship from generation to generation, the piece of furniture becomes a work of art made of the same art and with the same poetry that is handed down from generation to generation as OTELLO's literature.

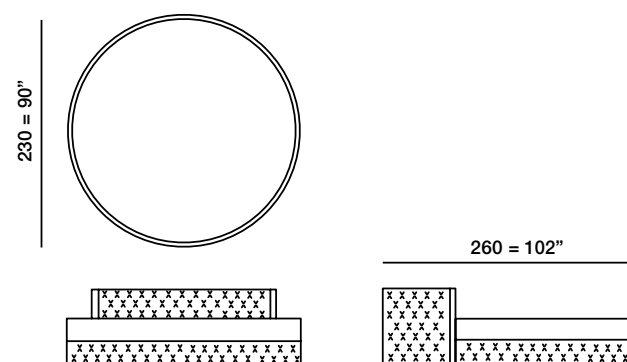



RONDÒ_

DESIGN R&S_ META DESIGN_

Design che coniuga egregiamente l'apparente "frivolità della forma rotonda, con l'elegante severità ed il massimo comfort. Suggestivo il design totale, con la maxi testiera attrezzata ad incorporare i due comodini. I ripiani in cristallo con i led ed il rullo consentono di personalizzare questo letto secondo il proprio gusto.

Design which brings together in a distinguished manner, the apparent "frivolity" of its round shape, with a severe elegance and maximum comfort. Evocative total design, with an imposing headboard equipped to incorporate two bedside cabinets. The crystal shelves with led lights and the roller enable this bed to be personalised according to personal tastes.

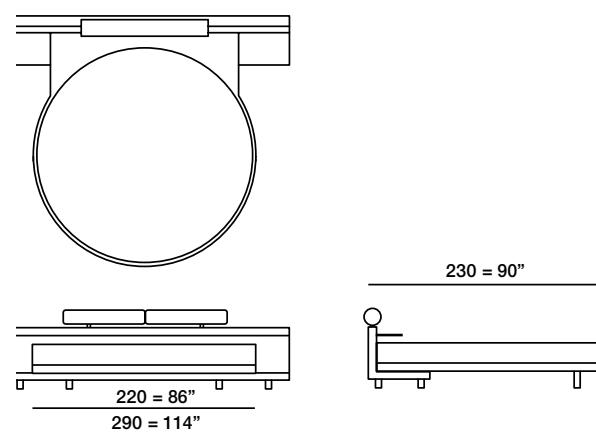



RONDÒ





RONDÒ

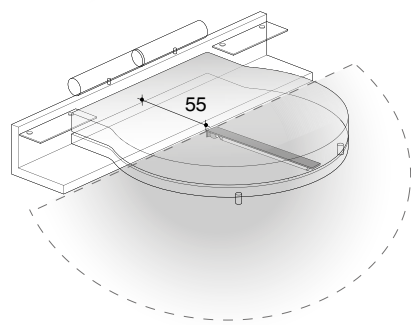

LUCE CON SENSORE DI PRESENZA
LIGHT WITH SENSOR OF PRESENCE

OTELLO SOMMIER_

DESIGN R&S_ META DESIGN_

SOMMIER rotondo, dalle linee molto pulite ed alto da terra, che garantisce il massimo effetto nell'arredo della propria camera da letto.

Round SOMMIER, which offers a linear design and is elevated, ensures the maximum effect in the furnishing of your bed room.

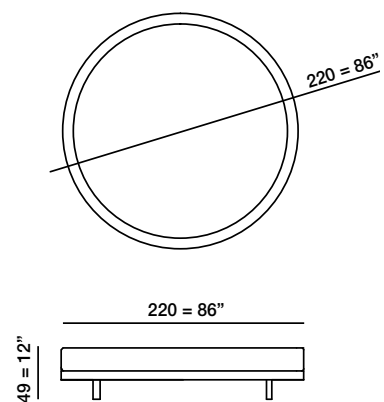



OTELLO_ OTELLO SOMMIER_ MOTORIZZATI

DESIGN R&S_ META DESIGN_

OTELLO MOTORIZZATO: IL PROTAGONISTA IN MOVIMENTO DELLA ZONA NOTTE.
Otello motorizzato nasce dalla linea classica del letto OTELLO.
Alle forme che contraddistinguono OTELLO abbiamo unito il movimento rotatorio circolare telecomandato che rende l'intero sistema letto unico nel suo genere sia per il design che per l'originalità.

OTELLO WITH ELECTRICAL MOVEMENT: THE STAR ON THE MOVE IN THE BEDROOM.
motorized Otello rises from the classic line OTELLO bed.
We have added, to the shapes that distinguish OTELLO model, a rotating motion circular remote control engine that makes the whole system unique in its kind both for its design and for its originality.



VIDEO DIMOSTRATIVO_
DEMONSTRATIVE VIDEO_

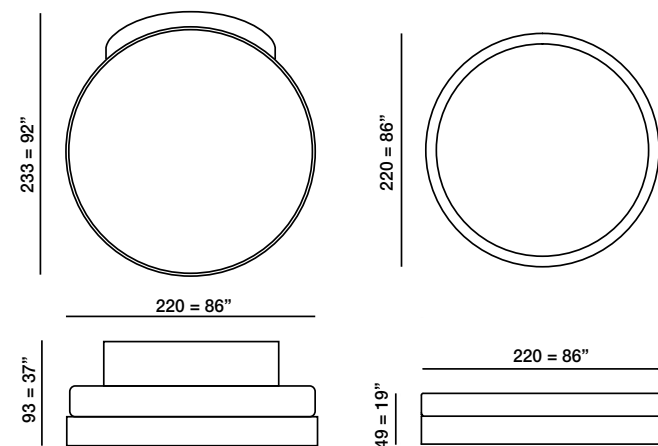

**SISTEMI
DI RETI
OPZIONALI_
OPTIONAL
NET FRAME
SYSTEMS_
SYSTEMS_**



DINAMICA_

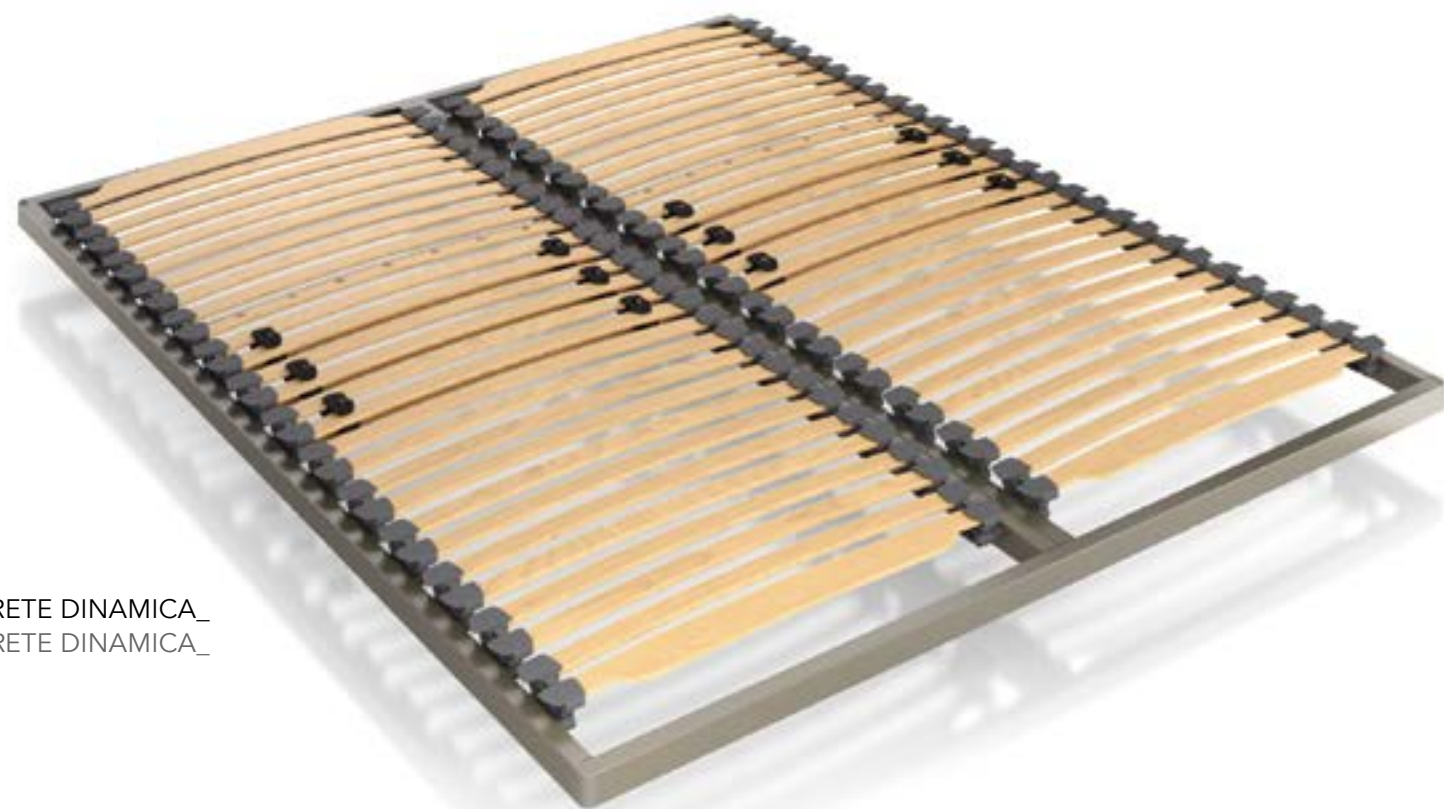

RETE DINAMICA_
RETE DINAMICA_

RETE DINAMICA BASCULANTE PER MATERASSI IN LATTICE, MEMORY FOAM E MOLLE INSACCHETTATE
DYNAMIC ADJUSTABLE SLATS BED SPRING FOR LATEX MEMORY FOAM AND INDIVIDUALLY NESTED POCKET SPRINGS

La rete a doghe dinamica è realizzata con doghe sottili di faggio da 38 mm. I porta doghe basculanti ammortizzati pensati per tale misura migliorano di molto il comfort del piano letto e distribuiscono il peso del corpo sulle estremità della doga, anziché sul centro, evitando quindi che con il tempo la doga si appiattisca o addirittura inverta la propria forma. La versione matrimoniale è ottenuta con l'accostamento di due piani d'appoggio singoli: per unire le due piazze è stato adottato un longherone centrale in tubolare che mantiene fra di esse il giusto grado di vicinanza. Ne risulta una rete a doghe matrimoniale di assoluto comfort e perfettamente ergonomica. Le doghe sottili da 38mm aiutano il corretto supporto anatomico del corpo. I regolatori di rigidità lombare, di serie nella rete a doghe matrimoniale amplificano i benefici apportati alla schiena, donandoci una maggiore rigenerazione nel sonno. Facili da usare, si regolano in pochi istanti in base al nostro peso corporeo.

Bed spring for dynamic slats is produced with slender beech slats 38 mm. The supporters for the dynamic and flexible slats are conceived in order to improve the comfort of the sleeping surface and allow to distribute the body weight to the extremities rather than in the middle. This avoids that with time the slat flattens or even worse that it inverts its shape. The bed spring for the double size version is obtained by matching alongside 2 single surfaces: for the joining the 2 single bed springs a central metal tubular bar has been applied which maintain the right closeness. The result is that we have a double size bed spring perfectly ergonomic and of absolute comfort. The slender slats of 38 mm are of help for a good anatomical body support. The lumbar adjustable regulators, supplied as standard in the double size bed spring, further improve the benefits for our backs., which also improves and regenerates us in our sleep. They are easy to use, and are adjustable in very few seconds according to the weight of our body and technological solutions are put together so as to create convertible comfortable and prestigious systems.

GAIA_



RETE MOTORIZZATA A SCOMPARSA_
RETE MOTORIZZATA A SCOMPARSA_

TELAIO_

Robusta struttura in legno multistrato con incastri angolari a coda di rondine ed eleganti piedi rastremati.

PIANO RIPOSO_

Sistema multidoga con sospensioni che alloggiavano tre doghe da 25, 38, 25 mm, a copertura totale del telaio. La maggiore altezza della doga da 38 mm favorisce microflussi d'aria, per una perfetta aerazione del materasso. Le doghe da 38 mm sono sagomate nella zona spalle, per garantire più elasticità, e sono dotate di regolatori di rigidità nella zona lombo-sacrale.

SOSPENSIONI_

Ammortizzatori multicella in HYTREL® *collocati sopra il telaio, per favorire un molleggio (flessione/oscillazione) più attivo delle singole doghe, con elevata indipendenza di movimento (ideale nelle combinazioni matrimoniali).

MOTORIZZAZIONE_

Doppia motorizzazione con pulsantiera, per una regolazione millimetrica delle alzate con movimenti indipendenti di testiera e pediera. I motori adottati sono certificati dalle ditte produttrici secondo le principali norme internazionali vigenti.

*HYTREL_

È un elastomero innovativo derivato dalla ricerca aerospaziale, che offre eccellenti prestazioni di flessibilità, resistenza e stabilità chimico-fisica.

FRAME_

Solid plywood frame with dovetailed corners and elegant conical feet.

SLEEPING SURFACE_

Multi-slat system with supports that hold three slats of 25, 38, 25 mm across the entire frame. The extra height of the 38 mm slat fosters air micro-fluxes for a perfect ventilation of the mattress. The 38 mm slats of the shoulder part are shaped to warrant higher elasticity and are provided with rigidity adjusters on the lumbar-sacral part.

SLAT SUPPORTS_

Multi-cell shock-absorbers of HYTREL fixed on the frame to allow a more active tilting (flexion / swinging) of every single slat, high independent movement (ideal for double bed combinations).

ELECTRIC MOTOR_

Double electric motor power with push-button control for a millimetric elevation adjustment with independent movements of head and foot part. All adopted electric motors are certified by their manufacturers in accordance with the main international standards.

*HYTREL_

is an innovative elastomere offering excellent flexibility, resistance and stability.



RETE MOTORIZZATA_
RETE MOTORIZZATA_



RETE MOTORIZZATA_
RETE MOTORIZZATA_



RETE MOTORIZZATA_
RETE MOTORIZZATA_

HANDY BOX_

RETI STRUTTURALI MOVIMENTATE_
FLOORSTANDING
ADJUSTABLE BED BASES_



MANIGLIA PER LETTO_
CONTENITORE STORAGE
BED HANDLE_

Maniglia standard Ilca ad asola in cordura agganciata al telaio con occhiello e rivetto. maniglia «ad arco».
Standard ilca loop handle made from cordura attached to frame with grommet and rivet. "arch" handle.



AVO A Y
DI SINCRONIZZAZIONE_
SYNCHRONIZED
MOVEMENT Y-CABLE_

Cavo a y di sincronizzazione per strutture motorizzate.
Synchronized movement y-cable for motorized adjustable structures.



KIT PER TRASMISSIONE
A RADIOFREQUENZA RADIO_
FREQUENCY TRANSMISSION
KIT_

Kit telecomando a radiofrequenza per strutture motorizzate con movimentazione a scomparsa.
Kit telecomando a radiofrequenza per strutture motorizzate con movimentazione a scomparsa.

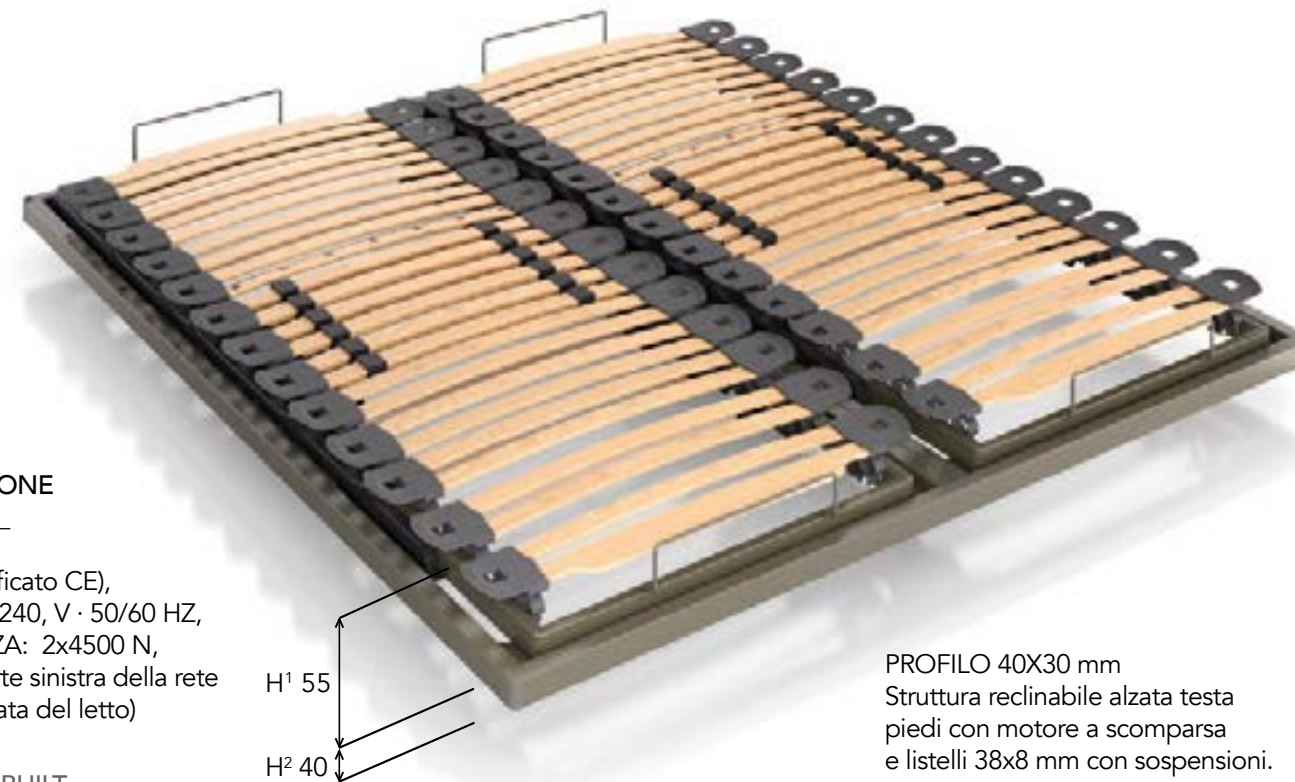

MOTORE CON
MOVIMENTAZIONE
A SCOMPARSA_

MOTORE: (certificato CE),
POTENZA: 230-240 V · 50/60 HZ,
MASSIMA FORZA: 2x4500 N,
POSIZIONE: parte sinistra della rete
(guardando testata del letto)

MOTOR WITH
DRIVE SYSTEM BUILT
INTO FRAME_

MOTOR: (CE certificate),
OUTPUT: 230-240 V, v · 50/60 hz,
MAXIMUM FORCE: 2x4500 N,
POSITION: left-hand side
of bed (looking at bed head)

H¹ 55
H² 40

PROFILO 40X30 mm
Struttura reclinabile alzata testa
piedi con motore a scomparsa
e listelli 38x8 mm con sospensioni.

40X30 mm PROFILE LIFT-UP
structure with head foot lift with
motor built into frame and 38x8
mm
slats with suspension system.

La struttura reclinabile alza testa/piedi ha un profilo di 40x30 mm ed è composta da motore a scomparsa e listelli 38x8 mm con sospensioni. La versione matrimoniale è formata dall'accostamento di due piani d'appoggio singoli per permettere la movimentazione delle due piazze in modo indipendente. Grazie ai 5 snodi del motore a scomparsa, l'utilizzatore raggiungerà un confort immediato; il motore con movimentazione a scomparsa a differenza del motore tradizionale, permette di utilizzare totalmente lo spazio sottostante del vano contenitore.

The reclining structure up head/foot has a 40x30 mm profile and consists of retractable engine and 38x8 mm strips with suspension. The double version has formed by the combination of two individual support surfaces to allow the movement of the two singles independently. With 5 joints of the retractable engine, the user will achieve an immediate comfort; unlike the traditional engine, allows to fully use the underlying compartment storage space.

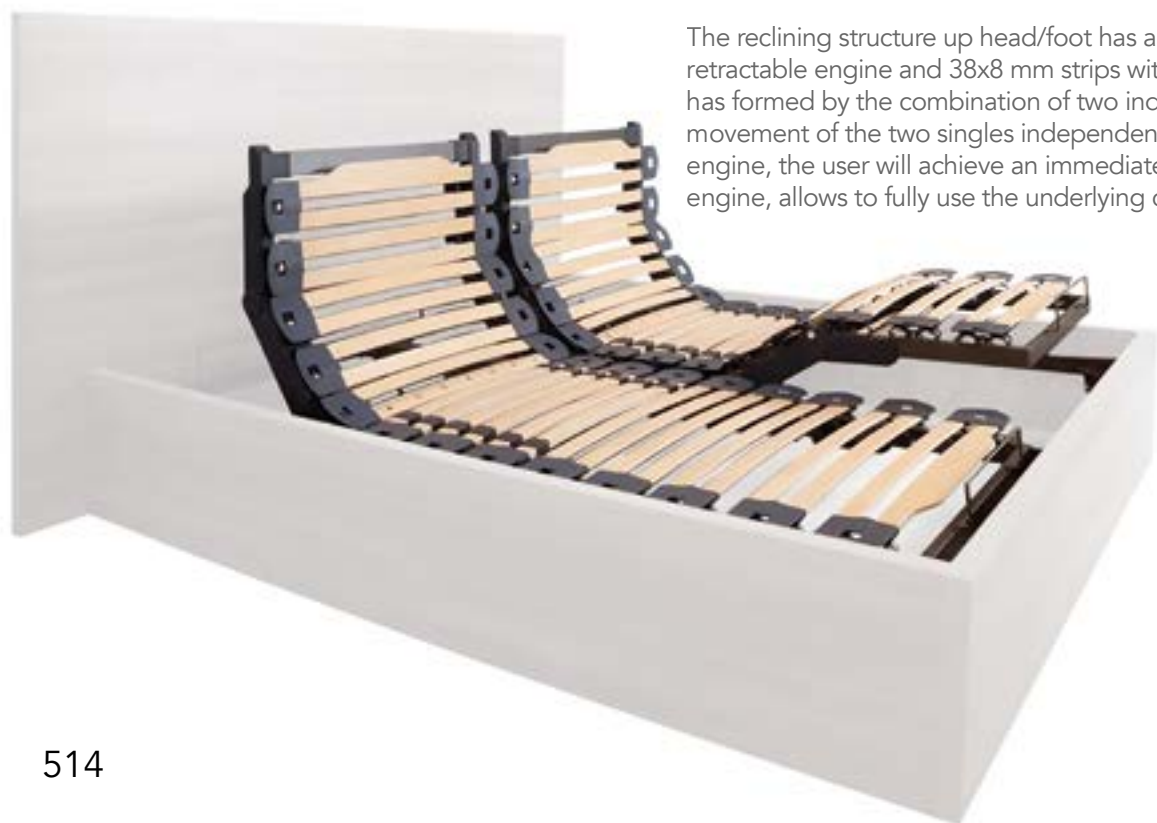

SISTEMA CON CONTENITORE
E RETE MATRIMONIALE
CON APERTURA A 45°_
Disponibile con telaio curvo
o con telaio copri testa raggiato
in polietilene.



SYSTEM WITH INTERNAL
STORAGE AND DOUBLE BED
BASE WITH 45° OPENING_
available with curved frame
or frame with polyethylene
rounded corners.

TECNICA LETTI_

BED FEATURES_



PROFILI_

PROFILES_

Profili ferma materasso in acciaio verniciato polvere.
Profiles mattress stoppers in powder coated steel.



INTERNO_

INTERNAL_

Maniglia in ABS verniciato alluminio per un agevole sollevamento del fondo e per pulizia, rivestimento interno in melamico facile da pulire ed igienico.

ABS handle painted aluminum for easy raising of the bottom and for cleaning, internal covering are in melamine for easy cleaning and hygenic.



SUPPORTO CENTRALE_

CENTRAL SUPPORT_

Supporto centrale reggi fondi per evitare deformazioni della struttura derivanti dalle spinte impresse dal meccanismo di movimentazione della rete.

Central support for bottom panels to avoid deformation of the structure caused by the thrust of the slat movement mechanism.



FETTUCIA IN TESSUTO TECNICO_

TECHNICAL FABRIC HANDLE_

Fettuccia in tessuto tecnico per un facile sollevamento della rete.
Technical fabric handle for easy opening of the net.



MECCANISMO ALZALETTO_

LIFTING MECHANISM_

Meccanismo alzaletto tradizionale ed orizzontale (vedi foto) e con molle a gas.
Lifting mechanism for traditional and horizontal system (see photo) and with gas springs.



PIEDINO CENTRALE REGOLABILE_

ADJUSTABLE CENTRAL LEG_

Piedino centrale regolabile per un perfetto adattamento a tutti i pavimenti anche irregolari.
Adjustable central leg for a perfect fit also for uneven floors.



TECNICA LETTI_

BED FEATURES_

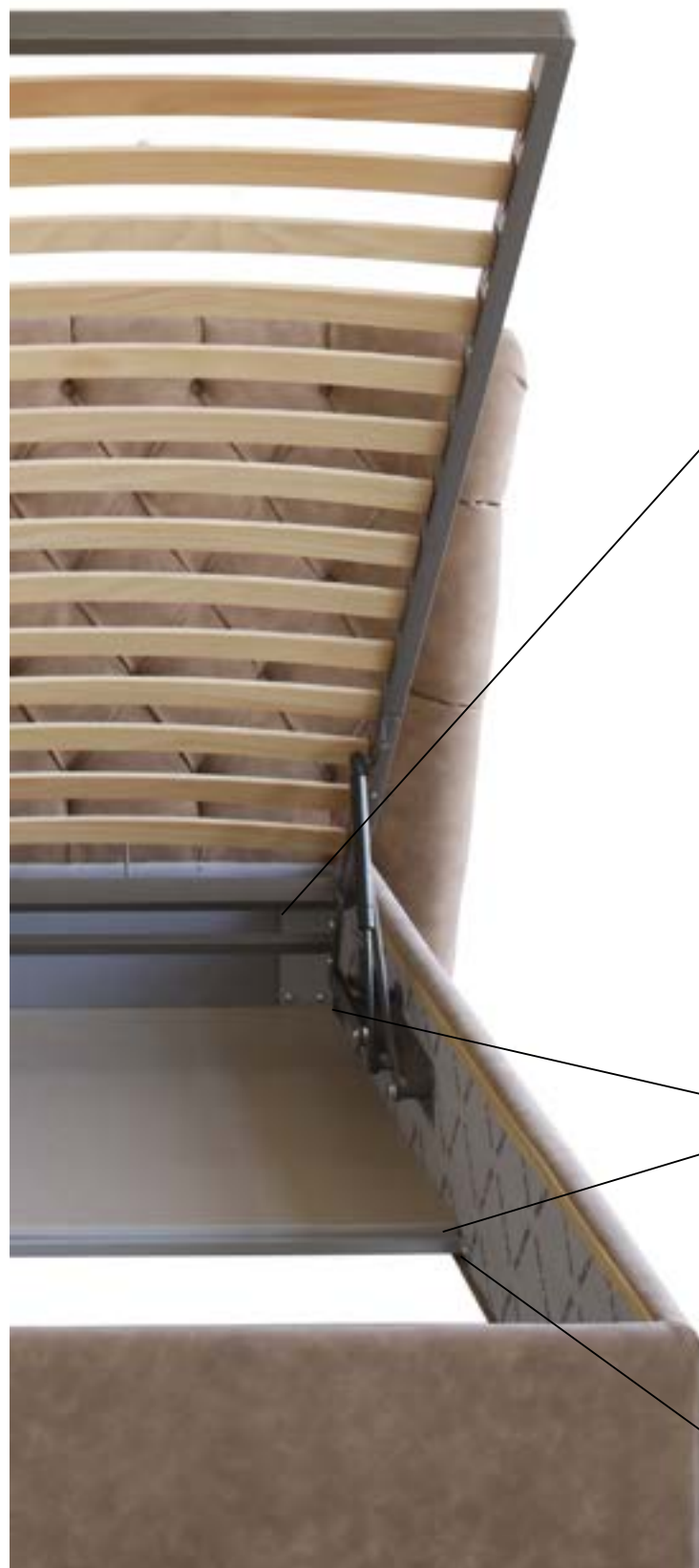

ANGOLARE IN METALLO STANDARD_
SUPPORT METAL FRAME_

Angolare in metallo standard per rete in appoggio.
Standard metal corner support for net



ANGOLARE IN METALLO REGOLABILE_
ADJUSTABLE METAL BRACKET_

Angolare in metallo regolabile per posizionamento rete in 4 diverse altezze.
adjustable metal bracket for positioning of the net in 4 different heights.



PUNTO DI APPOGGIO_
SUPPORT METAL FRAME_

Punto di appoggio del fondo fissato al centro della pediera e della testiera.
Support metal frame fixed to the center of the footboard and headboard.

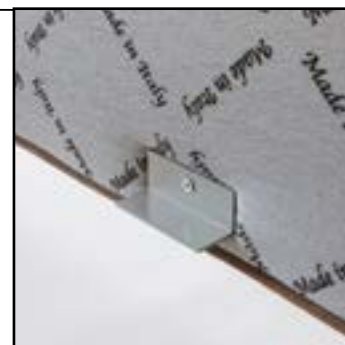

SACCO COPRIRETE ELASTICO BIFACCIALE_

ELASTIC BAG NET TO COVER SLATTED BED_

Un utile accessorio da posizionare attorno alla rete a doghe, che permette di nascondere le lenzuola e la biancheria quando queste sono rimboccate attorno al materasso. In questo modo, all'apertura del box contenitore, non si scorderà tra le doghe tutto ciò che sta sotto al materasso, ma si vedrà un telo elastico nero, che renderà il tutto molto ordinato e piacevole alla vista.

A useful accessory to be positioned around the wooden slat net, which allows to hide the sheets and the lingerie when they are tucked in around the mattress. Like this, when you lift the mattress to have access to the underneath storing box you will not see within the slats all that is underneath the mattress. You will only see a black elastic cloth which makes it all very orderly and pleasant to the sight.



SISTEMA MODULARE_
MODULAR SYSTEM_

Sistema modulare per reti single e con altezza variabile
Modular system for single nets and with height regulation



PIEDINI
LETTO_
BED
FEET_



PIEDINI LETTO_

BED FEET_

PIEDINO A_
FOOT A_

Quadrato in acciaio inox h. 50 mm
Square stainless steel h. 50 mm = 2"



PIEDINO B_
FOOT B_

Quadrato in acciaio inox h. 50 mm
Square stainless steel h. 50 mm = 2"



PIEDINO C_
FOOT C_

Ruote ABS con freno h. 65 mm
ABS wheel with brake h. 65 mm = 2"



PIEDINO G_
FOOT G_

Alluminio cromato lucido h.80 mm
Chromed aluminum h.80 mm = 4"



PIEDINO H_
FOOT H_

Cipolla in legno faggio verniciato wengé h.80mm

Onion shaped in beech wood stained wengé col
h.80 mm = 3"



PIEDINO L_
FOOT L_

Legno di faggio tinta ciliegio h.95 mm
Beech wood stained cherry col. h.95 mm = 4"



PIEDINO D_
FOOT D_

Cubo in legno col wengé h.75 mm
Wooden cube col. wenge h.75 mm = 3"



PIEDINO E_
FOOT E_

Alluminio cromato lucido h.100 mm
Chromed aluminum h.100 mm = 4"



PIEDINO F_
FOOT F_

Alluminio satinato lucido h.100 mm
Satin aluminum h.100 mm = 4"



PIEDINO L_
FOOT L_

Legno di faggio tinta wengé con bordino cromato
h.85 mm
Beech wood stained wengé col. with chrome
edging h.85 mm = 2"



PIEDINO M_
FOOT M_

Stelo alluminio cromato h.150mm
Chromed aluminum stem h.150 mm = 6"



PIEDINO N_
FOOT N_

Legno di faggio tinta ciliegio h.60 mm
Beech wood stained cherry col. h.60 mm = 2"



CUSCINI_
CUSHIONS_



CUSCINI_ CUSHIONS_

CUSCINO MISTO PIUMA_
MIX FEATHER CUSHION_

ART. 2971_ 60X60 = 24X24"

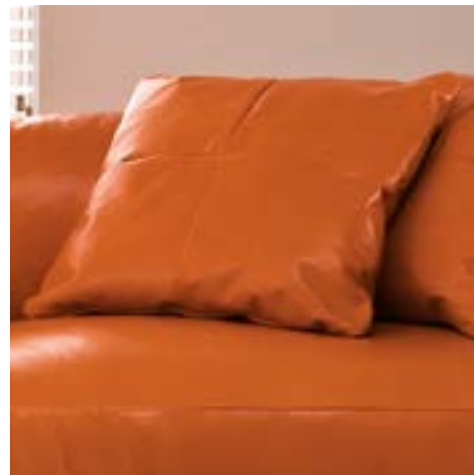

CUSCINO MISTO PIUMA_
MIX FEATHER CUSHION_

ART. 2972_ 50X50 = 20X20"



CUSCINO MISTO PIUMA_
MIX FEATHER CUSHION_

ART. 2962_ 46X46 = 18X18"



CUSCINO DI POLIURETANO_
POLYURETHANE FOAM CUSHION_

ART. 504_ 60X50 = 24X20"
ART. 505_ 80X50 = 31X20"



CUSCINO MISTO PIUMA_
MIX FEATHER CUSHION_

ART. 506_ 70X60 = 28X24"
ART. 507_ 90X60 = 35X24"

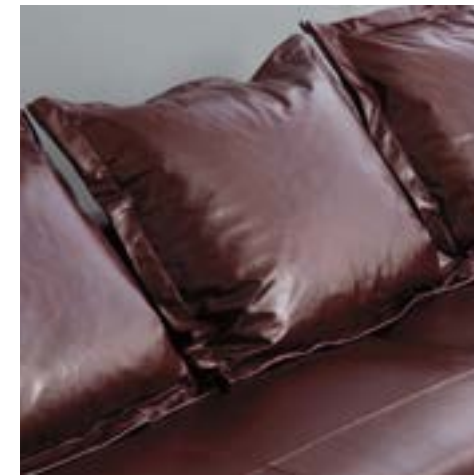

CUSCINO DI POLIURETANO_
POLYURETHANE FOAM CUSHION_

ART. 2963_ 43X43 = 17X17"



CUSCINO MISTO PIUMA_
MIX FEATHER CUSHION_

ART. 2973_ 60X40 = 24X16"

con profilo gros grain_ with gros grain trimming



CUSCINO MISTO PIUMA_
MIX FEATHER CUSHION_

ART. 2974_ 50X15 = 20X6"

con profilo gros grain_ with gros grain trimming

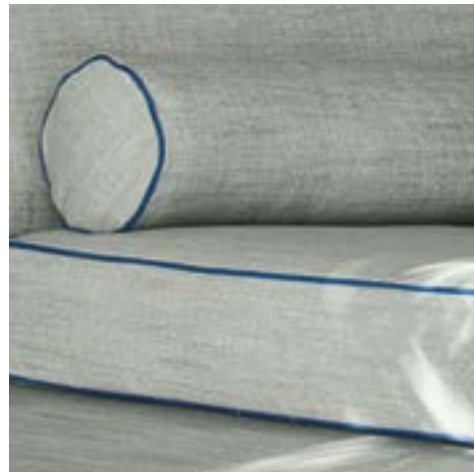

CUSCINO DI POLIURETANO_
POLYURETHANE FOAM CUSHION_

ART. 2975_ 70X30 = 28X12"



CUSCINO MISTO PIUMA_
MIX FEATHER CUSHION_

ART. 605_ 60X43 = 24X17"



CUSCINO MISTO PIUMA_
MIX FEATHER CUSHION_

ART. 606_ 50X15 = 20X6"

senza profilo gros grain_ without gros grain trimming

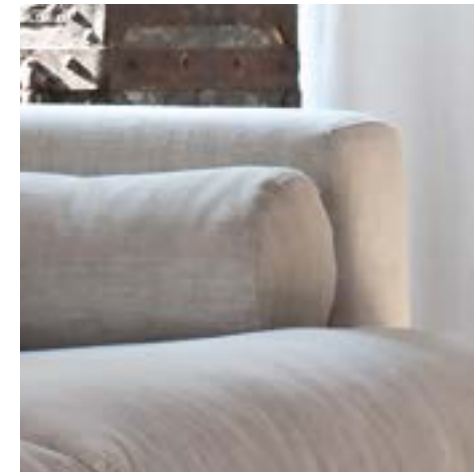

CUSCINO DI POLIURETANO_
POLYURETHANE FOAM CUSHION_

ART. 2976_ 65X45 = 26X18"



SPECCHIERE_
MIRRORS_





Meta[®]
D E S I G N

Via della Chiesa, 10 - loc. Villanova
33080 Prata di Pordenone (PN).

Tel: (39) 0434 622280

Fax: (39) 0434 605145

mail: info@meta-design.it

www.meta-design.it